



HYDRO PROFILE



User Manual

©2022 ADJ Products, LLC all rights reserved. Information, specifications, diagrams, images, and instructions herein are subject to change without notice. ADJ Products, LLC logo and identifying product names and numbers herein are trademarks of ADJ Products, LLC. Copyright protection claimed includes all forms and matters of copyrightable materials and information now allowed by statutory or judicial law or hereinafter granted. Product names used in this document may be trademarks or registered trademarks of their respective companies and are hereby acknowledged. All non-ADJ Products, LLC brands and product names are trademarks or registered trademarks of their respective companies.

ADJ Products, LLC and all affiliated companies hereby disclaim any and all liabilities for property, equipment, building, and electrical damages, injuries to any persons, and direct or indirect economic loss associated with the use or reliance of any information contained within this document, and/or as a result of the improper, unsafe, insufficient and negligent assembly, installation, rigging, and operation of this product.

DOCUMENT VERSION



Due to additional product features and/or enhancements, an updated version of this document may be available online.

Please check www.adj.com for the latest revision/update of this manual before beginning installation and/or programming.

| Date | Document Version | Software Version | DMX Channels | Notes |
|------------|------------------|------------------|------------------|--|
| 05/25/2022 | 1.0 | 1.01 | 36 / 50 / 57 Ch. | Initial Release. |
| 07/13/2022 | 1.1 | 1.02A | No Change | Added: Torque Settings for Screws. Updated: Features, Installation, Gobos, RDM, Control Panel, System Menu, Cleaning & Maintenance. |
| 07/19/2022 | 1.2 | N/C | No Change | Updated Dimensional Drawings and Specifications. |

Europe Energy Saving Notice

Energy Saving Matters (EuP 2009/125/EC)

Saving electric energy is a key to help protecting the environment. Please turn off all electrical products when they are not in use. To avoid power consumption in idle mode, disconnect all electrical equipment from power when not in use. Thank you!

TABLE OF CONTENTS

| | |
|----------------------------------|----|
| Introduction | 4 |
| Limited Warranty (USA Only) | 5 |
| Warranty Registration Features | 6 |
| Safety Guidelines | 7 |
| Overview | 8 |
| Installation | 9 |
| Remote Device Management (RDM) | 12 |
| Gobos | 13 |
| Control Panel | 16 |
| System Menu | 17 |
| DMX Setup | 20 |
| DMX Traits | 22 |
| Color Wheel Animation Wheel | 31 |
| White Color Temperature Chart | 32 |
| Frame Macros Chart | 33 |
| Dim Speeds | 34 |
| Dimmer Modes | 35 |
| Cleaning and Maintenance | 36 |
| Torque Settings for Screws | 38 |
| Dimensional Drawings | 40 |
| Error Codes | 41 |
| Specifications | 42 |

INTRODUCTION

Unpacking: Thank you for purchasing the Hydro Profile by ADJ Products, LLC. Every device has been thoroughly tested and has been shipped in perfect operating condition. Carefully check the shipping carton for damage that may have occurred during shipping. If the carton appears to have been damaged, carefully inspect your fixture for any damage and be sure all accessories necessary to operate the unit have arrived intact. In the event that damage has been found or parts are missing, please contact our toll free customer support number for further instructions. Do not return this unit to your dealer without first contacting customer support.

Introduction: The ADJ Hydro Profile is a DMX intelligent, weather-proof LED moving head fixture. To optimize the performance of this product, please read these operating instructions carefully in order to familiarize yourself with the basic operations of this unit. These instructions contain important safety information regarding the use and maintenance of this unit. Please keep this manual with the unit for future reference.

Customer Support: Contact ADJ Service for any product related service and support needs. Also visit forums.adj.com with questions, comments or suggestions.

Parts: To purchase parts online visit:

<http://parts.adj.com> (US)

<http://www.adjparts.eu> (EU)

ADJ SERVICE USA - Monday - Friday 8:00am to 4:30pm PST

Voice: 800-322-6337 | Fax: 323-582-2941 | support@adj.com

ADJ SERVICE EUROPE - Monday - Friday 08:30 to 17:00 CET

Voice: +31 45 546 85 60 | Fax: +31 45 546 85 96 | support@adj.eu

ADJ PRODUCTS LLC USA

6122 S. Eastern Ave. Los Angeles, CA. 90040

323-582-2650 | Fax 323-532-2941 | www.adj.com | info@adj.com

ADJ SUPPLY Europe B.V

Junostraat 2 6468 EW Kerkrade, The Netherlands

+31 (0)45 546 85 00 | Fax +31 45 546 85 99

www.americandj.eu | info@americandj.eu

ADJ PRODUCTS GROUP Mexico

AV Santa Ana 30 Parque Industrial Lerma, Lerma, Mexico 52000

+52 (728) 282-7070

CAUTION! There are no user serviceable parts inside this unit. Do not attempt any repairs yourself, as doing so will void your manufacturer's warranty. In the unlikely event your unit may require service, please contact ADJ Products, LLC.

Do not discard the shipping carton in the trash. Please recycle when ever possible.

LIMITED WARRANTY (USA ONLY)

- A. ADJ Products, LLC hereby warrants, to the original purchaser, ADJ Products, LLC products to be free of manufacturing defects in material and workmanship for a prescribed period from the date of purchase (see specific warranty period on reverse). This warranty shall be valid only if the product is purchased within the United States of America, including possessions and territories. It is the owner's responsibility to establish the date and place of purchase by acceptable evidence, at the time service is sought.
- B. For warranty service, you must obtain a Return Authorization number (RA#) before sending the product back—please contact ADJ Products, LLC Service Department at 800-322-6337. Send the product only to the ADJ Products, LLC factory. All shipping charges must be prepaid. If the requested repairs or service (including parts replacement) are within the terms of this warranty, ADJ Products, LLC will pay return shipping charges only to a designated point within the United States. If the entire instrument is sent, it must be shipped in its original package and packaging material. No accessories should be shipped with the product. If any accessories are shipped with the product, ADJ Products, LLC shall incur no liability whatsoever for loss of or damage to any such accessories, nor for the safe return thereof.
- C. This warranty is void if the product serial number and/or labels are altered or removed; if the product is modified in any manner which ADJ Products, LLC concludes, after inspection, affects the reliability of the product; if the product has been repaired or serviced by anyone other than the ADJ Products, LLC factory unless prior written authorization was issued to purchaser by ADJ Products, LLC; if the product is damaged because it was not properly maintained as set forth in the product instructions, guidelines and/or user manual.
- D. This is not a service contract, and this warranty does not include maintenance, cleaning, or periodic check-up. During the period specified above, ADJ Products, LLC will replace defective parts at its expense with new or refurbished parts, and will absorb all expenses for warranty service and repair labor by reason of defects in material or workmanship. The sole responsibility of ADJ Products, LLC under this warranty shall be limited to the repair of the product, or replacement thereof, including parts, at the sole discretion of ADJ Products, LLC. All products covered by this warranty were manufactured after August 15, 2012, and bear identifying marks to that effect.
- E. ADJ Products, LLC reserves the right to make changes in design and/or improvements upon its products without any obligation to include these changes in any products theretofore manufactured.
- F. No warranty, whether expressed or implied, is given or made with respect to any accessory supplied with products described above. Except to the extent prohibited by applicable law, all implied warranties made by ADJ Products, LLC in connection with this product, including warranties of merchantability or fitness, are limited in duration to the warranty period set forth above. And all warranties, whether expressed or implied, including warranties of merchantability or fitness, are limited in duration to the warranty period set forth above. The consumer's and/or dealer's sole remedy shall be such repair or replacement as is expressly provided above; and under no circumstances shall ADJ Product, LLC be liable for any loss and/or damage, direct and/or consequential arising out of the use of, and/or inability to use this product.
- G. This warranty is the only written warranty applicable to ADJ Products, LLC products, and supersedes all prior warranties and written descriptions of warranty terms and conditions heretofore published.

MANUFACTURER'S LIMITED WARRANTY PERIODS:

- Non-LED Lighting Products = 1-Year (365 Days) (Including Special Effect Lighting, Intelligent Lighting, UV lighting, Strobes, Fog Machines, Bubble Machines, Mirror Balls, Par Cans, Trussing, Lighting Stands, Power/Data Distribution, etc. excluding LED and lamps)
- Laser Products = 1-Year (365 Days) (excluding laser diodes which have a 6-Month Limited Warranty)
- LED Products = 2-Year (730 Days) (excluding batteries which have a 180 Day Limited Warranty)
- NOTE: 2-Year (730 Days) Limited Warranty ONLY applies to product purchased within the United States. StarTec Series = 1-Year (365 Days) (excluding batteries which have a 180 Day Limited Warranty)
- ADJ DMX Controllers = 2 Year (730 Days)
- American Audio Products = 1 Year (365 Days)

WARRANTY RETURNS

Please fill out the enclosed warranty card to validate your purchase. All returned service items, whether under warranty or not, must be freight pre-paid and accompanied by a return authorization (R.A.) number. The R.A. number must be clearly written on the outside of the return package. A brief description of the problem as well as the R.A. number must also be written down on a piece of paper included in the shipping carton. If the unit is under warranty, you must provide a copy of your proof of purchase invoice. You may obtain an R.A. number by contacting our customer support team on our customer support number. All packages returned to the service department not displaying an R.A. number on the outside of the package will be returned to the shipper.

FEATURES

The Hydro Profile is ADJ's first weatherproof moving head profile fixture, which combines a potent 660-Watt cool white LED light engine with an impressive 25,000+ Lumens, and an expansive feature set to deliver a truly powerful and versatile luminaire.

INCLUDED ITEMS

- Omega Bracket (x2)
- Locking Power Cable (x1)

IP RATING

An IP rated lighting fixture is commonly installed in outdoor environments and has been designed with an enclosure that effectively protects the ingress (entry) of external foreign objects such as dust and water. The Ingress Protection (IP) rating system is commonly expressed as "IP" followed by two numbers (i.e. IP65), where the numbers define the degree of protection. The first digit (Foreign Bodies Protection) indicates the extent of protection against particles entering the fixture, while the second digit (Water Protection) indicates the extent of protection against water entering the fixture.

An IP65 rated lighting fixture, such as this one, is dust tight, and protected against low pressure water jets from any direction.

SAFETY GUIDELINES

THIS FIXTURE IS COMPOSED OF SOPHISTICATED ELECTRONIC COMPONENTS. TO GUARANTEE SMOOTH OPERATION, IT IS IMPORTANT TO FOLLOW ALL INSTRUCTIONS AND GUIDELINES IN THIS MANUAL. ADJ PRODUCTS, LLC IS NOT RESPONSIBLE FOR INJURY AND/OR DAMAGES RESULTING FROM THE MISUSE OF THIS FIXTURE DUE TO THE DISREGARD OF THE INFORMATION PRINTED IN THIS MANUAL. ONLY QUALIFIED AND/OR CERTIFIED PERSONNEL SHOULD PERFORM INSTALLATION OF THIS FIXTURE AND ONLY THE ORIGINAL RIGGING PARTS INCLUDED WITH THIS FIXTURE SHOULD BE USED FOR INSTALLATION. ANY MODIFICATIONS TO THE FIXTURE AND/OR THE INCLUDED MOUNTING HARDWARE WILL VOID THE ORIGINAL MANUFACTURER'S WARRANTY AND INCREASE THE RISK OF DAMAGE AND/OR PERSONAL INJURY. ONLY CERTIFIED PERSONNEL SHOULD PERFORM INSTALLATION OF THIS FIXTURE.

- PROTECTION CLASS 1 - FIXTURE MUST BE PROPERLY GROUNDED.
- THERE ARE NO USER SERVICEABLE PARTS INSIDE THIS UNIT.
- DO NOT ATTEMPT ANY REPAIRS YOURSELF; DOING SO WILL VOID YOUR MANUFACTURER'S WARRANTY. DAMAGES RESULTING FROM MODIFICATIONS TO THIS FIXTURE AND/OR THE DISREGARD OF SAFETY INSTRUCTIONS AND GUIDELINES IN THIS MANUAL VOID THE MANUFACTURER'S WARRANTY AND ARE NOT SUBJECT TO ANY WARRANTY CLAIMS AND/OR REPAIRS.
- DO NOT PLUG FIXTURE INTO A DIMMER PACK!
- NEVER OPEN THIS FIXTURE WHILE IN USE!
- UNPLUG POWER BEFORE SERVICING FIXTURE!
- NEVER TOUCH FIXTURE DURING OPERATION, AS IT MAY BE HOT!
- KEEP FLAMMABLE MATERIALS AWAY FROM FIXTURE!
- NEVER LOOK DIRECTLY INTO THE LIGHT SOURCE!
- RETINA INJURY RISK - MAY INDUCE BLINDNESS!
- SENSITIVE PERSONS MAY SUFFER AN EPILEPTIC SHOCK!
- MINIMUM DISTANCE TO OBJECTS/SURFACES IS 6.6 FEET (2 METERS)
- **MAXIMUM AMBIENT TEMPERATURE IS 113° F (45°C). DO NOT OPERATE THE DEVICE WHEN AMBIENT TEMPERATURE EXCEEDS THIS VALUE.**
- **MINIMUM DISTANCE TO FLAMMABLE MATERIALS FROM THE SURFACE IS 1.6 FEET (0.5 METER).**
- DO NOT TOUCH the fixture housing during operation. Turn OFF the power and allow approximately 60 minutes for the fixture to cool down before servicing.
- DO NOT shake fixture, and avoid brute force when installing and/or operating fixture.
- DO NOT operate fixture if the power cord is frayed, crimped, damaged and/or if any of the power cord connectors are damaged and do not insert into the fixture securely with ease. NEVER force a power cord connector into the fixture. If the power cord or any of its connectors are damaged, replace it immediately with a new one of the same power rating.
- DO NOT block any air ventilation slots. All fan and air inlets must remain clean and never blocked. Allow approx. 6" (15cm) between fixture and other devices or a wall for proper cooling.
- When installing fixture in a suspended environment, always use mounting hardware that is no less than M10 x 25 mm, and always install fixture with an appropriately rated safety cable.
- Always disconnect fixture from main power source before performing any type of service and/or cleaning procedure.
- Only handle the power cord by the plug end. Never pull out the plug by tugging the wire portion of the cord.
- During the initial operation of this fixture, a light smoke or smell may emit from the interior of the fixture. This is a normal process and is caused by excess paint in the interior of the casing burning off from the heat associated with the lamp and will decrease gradually over time.
- Consistent operational breaks will ensure fixture will function properly for many years.
- ONLY use original packaging and materials to transport the fixture for service.

OVERVIEW

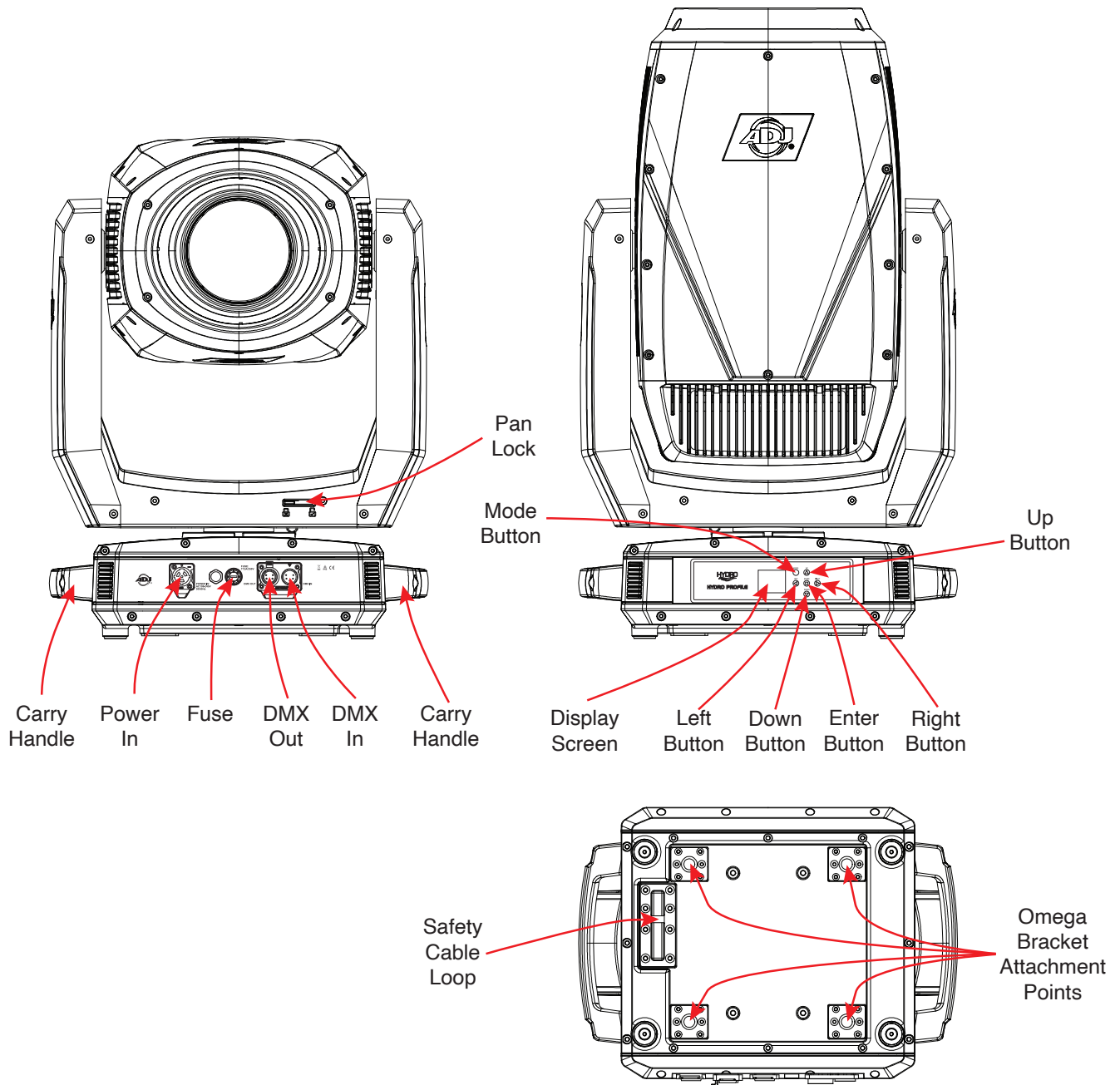

INSTALLATION



FLAMMABLE MATERIAL WARNING

Keep fixture minimum 5.0 feet (1.5m) away from flammable materials and/or pyrotechnics.



ELECTRICAL CONNECTIONS

A qualified electrician should be used for all electrical connections and/or installations.



MINIMUM DISTANCE TO OBJECTS/SURFACES IS 6.6 FEET (2 METERS).

MINIMUM DISTANCE OF FLAMMABLE MATERIALS FROM THE SURFACE IS 1.6 FEET (0.5 METER)

DO NOT INSTALL THE FIXTURE IF YOU ARE NOT QUALIFIED TO DO SO!

- Fixture **MUST** be installed following all local, national, and country commercial electrical and construction codes and regulations.
- Before rigging/mounting a single fixture or multiple fixtures to any metal truss/structure or placing the fixture(s) on any surface, a professional equipment installer **MUST** be consulted to determine whether the metal truss/structure or surface is properly certified to safely hold the combined weight of the fixture(s), clamps, cables, and accessories.
- Maximum fixture ambient operating temperature is **113°F (45°C)**. Do not use operate the fixture when ambient temperature exceeds this value!
- Fixture(s) should be installed outside walking paths, seating areas, or areas were unauthorized personnel might reach the fixture by hand.
- **NEVER** stand directly below the fixture(s) when rigging, removing, or servicing.
- Overhead fixture installation must always be secured with a secondary safety attachment, such as an appropriately rated safety cable.
- Allow approximately 60 minutes for the fixture to cool down before servicing.

IP RATING

An IP rated lighting fixture is commonly installed in outdoor environments and has been designed with an enclosure that effectively protects the ingress (entry) of external foreign objects such as dust and water. The Ingress Protection (IP) rating system is commonly expressed as “IP” followed by two numbers (i.e. IP65), where the numbers define the degree of protection. The first digit (Foreign Bodies Protection) indicates the extent of protection against particles entering the fixture, while the second digit (Water Protection) indicates the extent of protection against water entering the fixture.

An IP65 rated lighting fixture, such as this one, is dust tight, and protected against low pressure water jets from any direction.

RIGGING

Overhead rigging requires extensive experience, including calculating working load limits, knowledge about installation materials being used, and periodic safety inspection of all installation material and the fixture, among other skills. If you lack these qualifications, do not attempt the installation yourself. Improper installation can result in bodily injury.

INSTALLATION

CLAMP INSTALLATION

This fixture features a mounting points on the underside of the base for the attachment of Omega clamps. Make sure to always install the device using **both** Omega clamp mounting points. A loop for the attachment of a safety cable is also located on the underside of the base (see the illustration below). When mounting the fixture to a truss or any other suspended or overhead installation, be sure to secure an appropriately rated clamp (not included) to each Omega bracket, and attach a separate **SAFETY CABLE** of the appropriate weight rating to the safety cable loop.

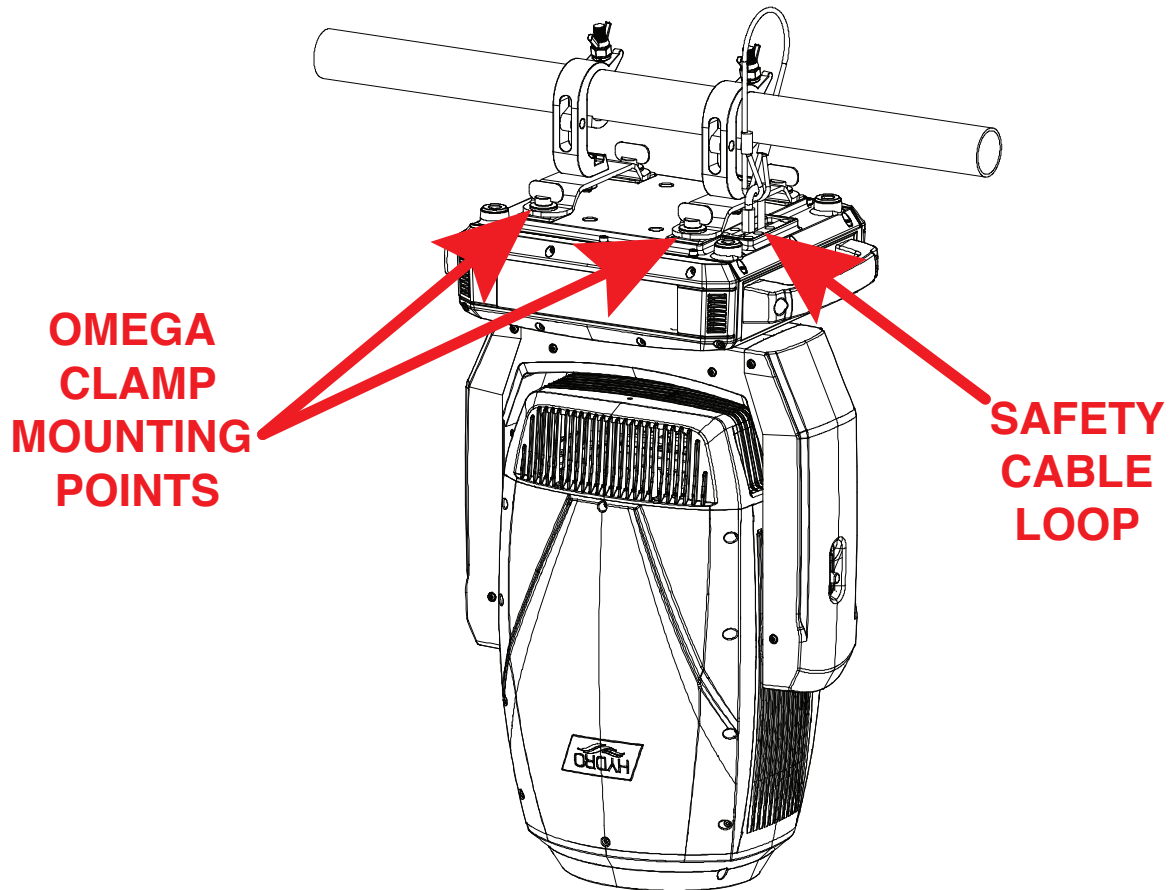

SAFETY CABLE:
**ALWAYS ATTACH A SAFETY CABLE WHENEVER INSTALLING THIS FIXTURE
IN A SUSPENDED ENVIRONMENT TO ENSURE THAT THE FIXTURE WILL NOT
FALL IF THE CLAMP FAILS.**

INSTALLATION

POTENTIAL INTERNAL FIXTURE DAMAGE FROM EXTERNAL SOURCES OF LIGHT BEAMS

External sources of light beams from direct sunlight, lighting moving head fixtures, and lasers which are focused directly towards the exterior housing and/or penetrate the front lens opening of ADJ lighting fixtures can cause severe internal damage, including burning of optics, dichroic color filters, glass and metal gobos, prisms, animation wheels, frost filters, irises, shutters, motors, belts, wiring, discharge lamps, and LEDs.

This issue is not unique to ADJ lighting fixtures, but rather it is a common issue with lighting fixtures from all manufacturers. Although there is no true way to completely prevent this issue from happening, the guidelines below can reduce the risk of any potential damage if followed. Contact ADJ Service for more details.

DO NOT EXPOSE THE FIXTURE AND/OR FRONT LENS OPENING TO LIGHT BEAMS FROM DIRECT SUNLIGHT, OTHER LIGHTING OR MOVING HEAD FIXTURES, AND LASERS DURING UNPACKING, INSTALLATION, USE, AND EXTENDED IDLE TIMES OUTDOORS. DO NOT FOCUS A LIGHT BEAM FROM ONE LIGHTING FIXTURE DIRECTLY TOWARDS ANOTHER.

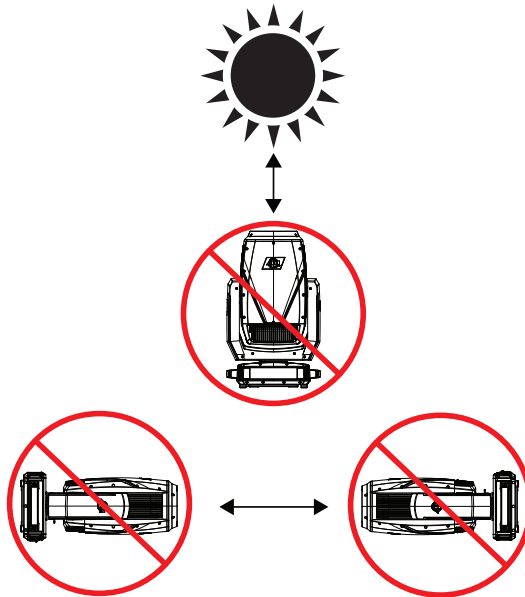

SUN PROTECTION MODE/ HIBERNATION MODE:

This state can be set via DMX, or the device will go into this state after 3 minutes without a DMX signal. This function can be switched on or off in the DMX traits (see the **DMX Traits** section for details). When the sun protection is activated, the pan-and-tilt function of the moving-head will position the lens away from direct sunlight, or other high intensity light source, to protect the internal belts, electronics etc. from burn damage.

When the unit is in the 'sun protection state', it uses its accelerometer sensors (X-Y-Z) (only present on discharge units and IP units) to position the front lens downwards, even when the unit(s) will be moved from its position. This will keep on changing the position of the head.

Please note that 'manual mode' overrides the 'sun-protection mode'. The hibernation function is an existing feature that puts the unit into a 'sleep state' to save power (this is a state where only the electronics remain on, and all other functions are turned off, functions such as motors lamps etc). This state is automatically activated when no DMX signal is present for the set time (1-99min or off).

REMOTE DEVICE MANAGEMENT (RDM)

NOTE: In order for RDM to work properly, RDM enabled equipment must be used throughout the entire system, including DMX data splitters and wireless systems.

Remote Device Management (RDM) is a protocol that sits on top of the DMX512 data standard for lighting, allowing the DMX systems of the fixtures to be modified and monitored remotely. This protocol is ideal for instances in which a unit is installed in a location that is not easily accessible.

With RDM, the DMX512 system becomes bi-directional, allowing a compatible RDM enabled controller to send out a signal to devices on the wire, as well as allowing the fixture to respond (known as a *GET* command). The controller can then use its *SET* command to modify settings that would typically have to be changed or viewed directly via the unit's display screen, including the DMX Address, DMX Channel Mode, and Temperature Sensors.

FIXTURE RDM INFORMATION:

| RDM Code | Device ID | Device Model ID | Personality ID |
|----------|--------------|-----------------|--|
| 0x1900 | 24 0000-FFFF | 24 | Basic 36 (1) Standard 50 (2) Extended 57 (3) |

Please be aware that **not all RDM devices support all RDM features**, and therefore it is important to check beforehand to ensure that the equipment that you are considering includes all of the features that you require.

The following parameters are accessible in RDM on this device:

| | |
|-----------------------------------|--------------------------------------|
| [0x0015] Comms Status | [0x00E1] DMX Personality Description |
| [0x0020] Queued Message | [0x0200] Sensor Definition |
| [0x0030] Status Messages | [0x0201] Sensor Value |
| [0x0031] Status ID Description | [0x0400] Device Hours |
| [0x0032] Clear Status ID | [0x0405] Device Power Cycles |
| [0x0080] Device Model Description | [0x0500] Display Invert |
| [0x0081] Manufacturer Label | [0x0501] Display Level |
| [0x0082] Device Label | [0x0600] Pan Invert |
| [0x0090] Factory Defaults | [0x0601] Tilt Invert |
| [0x00C1] Boot Software Version ID | [0x1001] Reset Device |
| [0x00E0] DMX Personality | |

GOBOS

DESIGNS

FIXED GOBOS

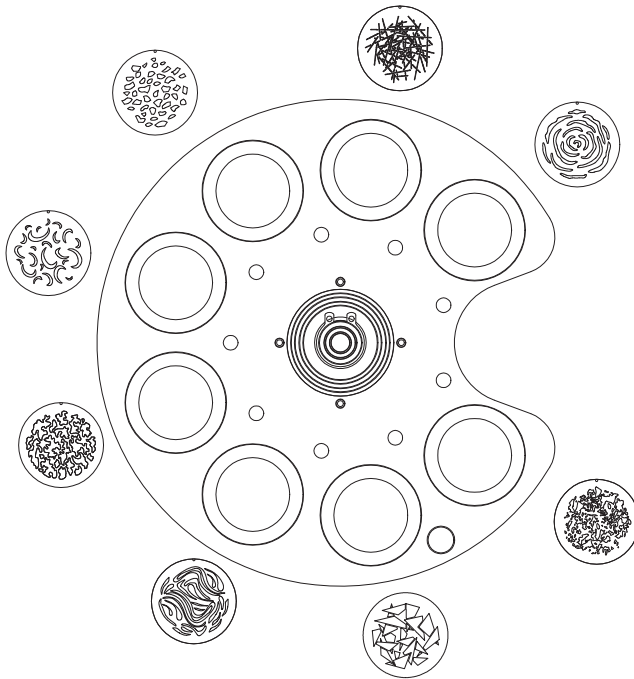

ROTATING GOBOS

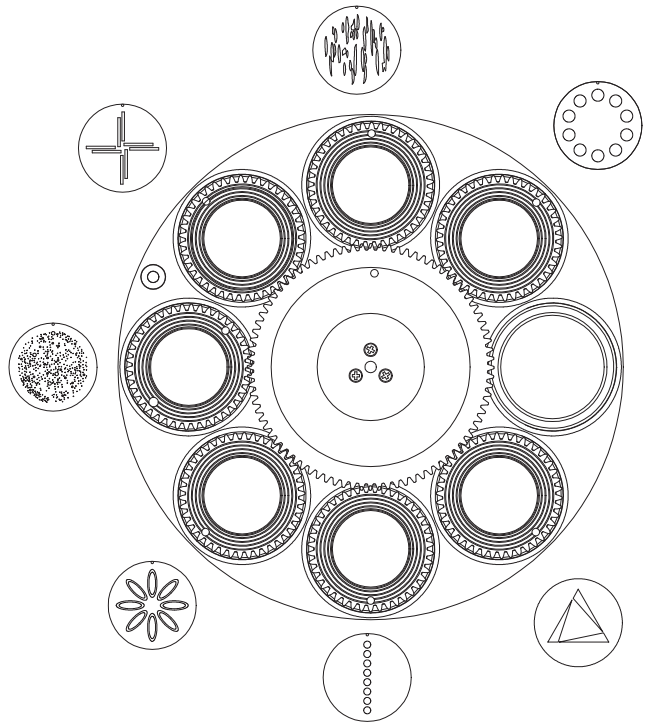

DIMENSIONS - FIXED GOBOS

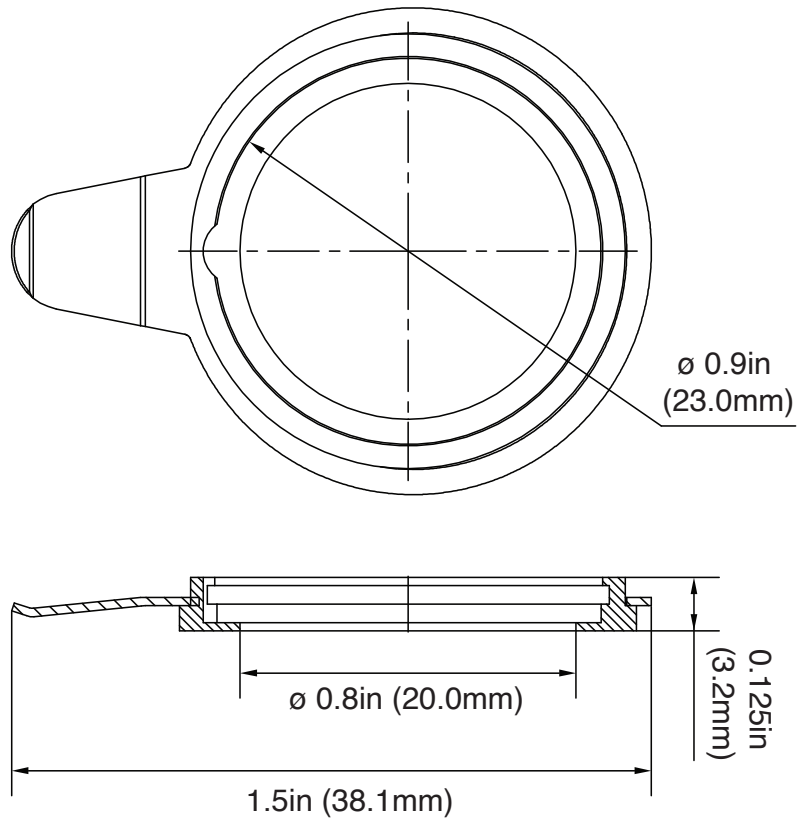

GOBOS

DIMENSIONS - ROTATING GOBOS

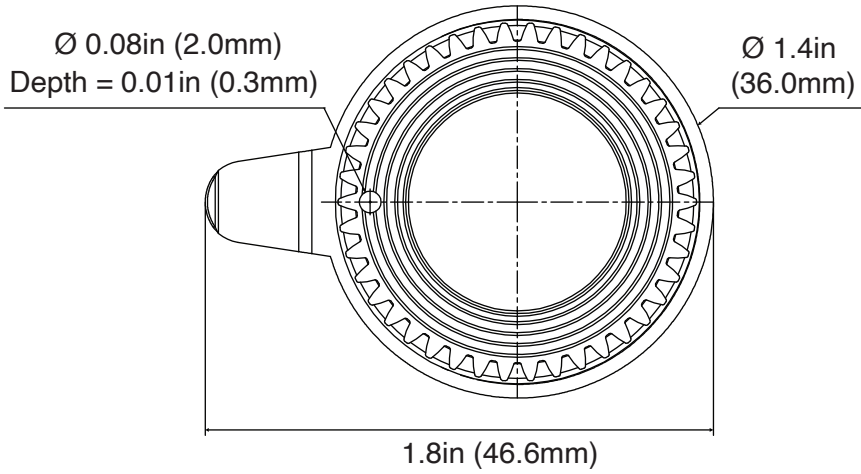

Note: Dotting and milling slot on the same tooth tip.

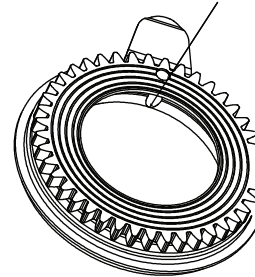

CRITICAL

$\text{Ø } 0.787\text{in } \begin{matrix} +0.003\text{in} \\ -0.001\text{in} \end{matrix}$
 (20.0mm $\begin{matrix} +0.07\text{mm} \\ -0.03\text{mm} \end{matrix}$)

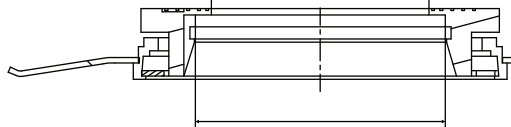

$\text{Ø } 0.906\text{in } \begin{matrix} +0.004\text{in} \\ -0.0008\text{in} \end{matrix}$
 (23.0mm $\begin{matrix} +0.10\text{mm} \\ -0.02\text{mm} \end{matrix}$)

CRITICAL

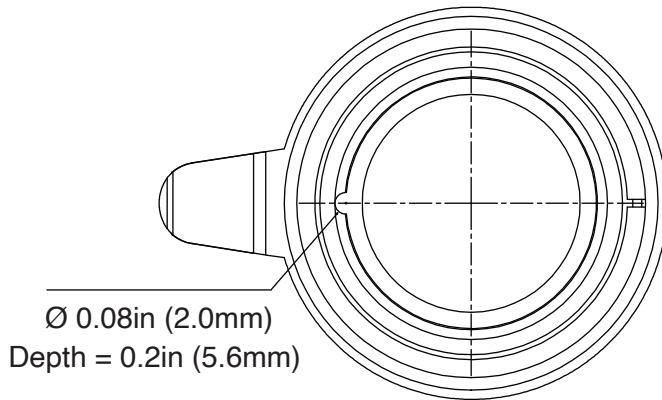

GOBOS

GOBO REPLACEMENT

1. Place the device on a flat, stable surface, and allow the device to cool down for at least 1 hour before beginning this procedure.
2. Engage both the pan and tilt locks, and remove the head covers.
3. Locate the gobo module (second module from the bottom, as shown in the illustration below). Disconnect any electrical connectors linking the module to the fixture head, and remove the screws holding the module in place. Slide the module out of the head.

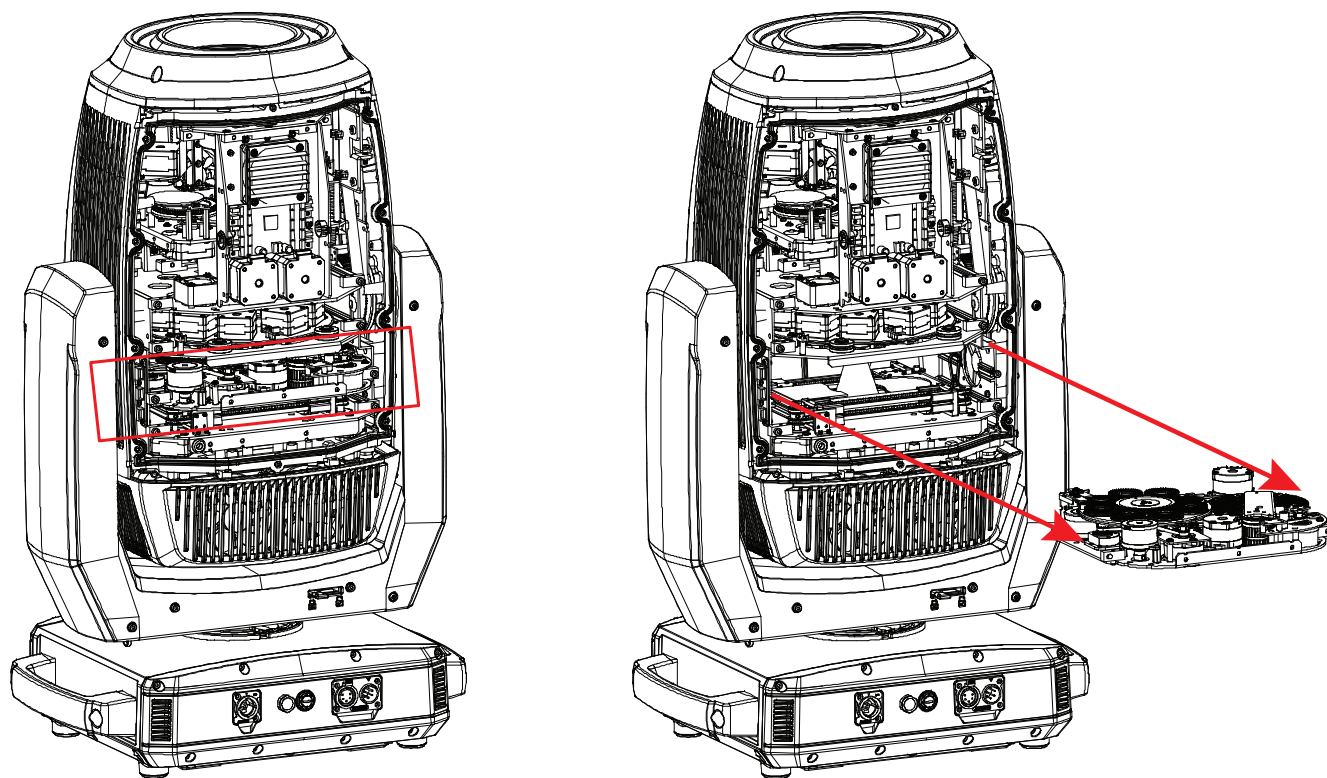

4. Pull the gobo holder away from the gobo wheel, then gently slide it outwards. Use a pair of needle nose pliers to carefully remove the retainer spring from the gobo holder. The gobo can now be removed from the gobo holder, and replaced with a new gobo. Reassemble by reversing these steps.

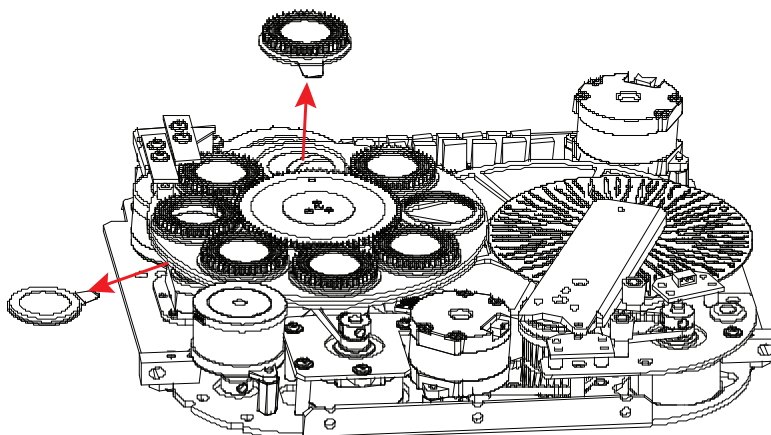

CONTROL PANEL

The fixture includes an easy to navigate system menu control panel display where all necessary settings and adjustments are made. (See image below)

- **MODE:** Cycles through the main menu options and/or return to previous menu without making changes.
- **ENTER:** Select highlighted option and/or confirm selection.
- **DOWN/UP/LEFT/RIGHT:** Use as a directional pad, or to scroll through menu options.

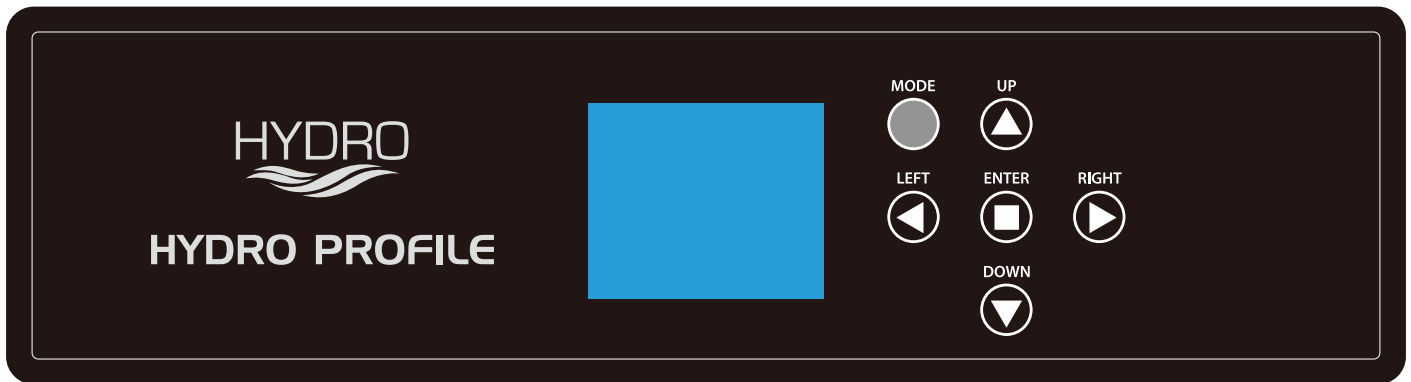

KEY LOCK

This function allows the user to configure whether or not the display screen and control panel keys will lock after a certain period of inactivity. It can be accessed by navigating to *Personality > Display > Key Lock* in the system menu. The setting options are described below:

- **OFF:** The display screen and control panel keys remain active at all times.
- **ON:** The display screen and control panel keys automatically lock after a certain period of inactivity, which can be set under *Personality > Display > Screen Saver Delay*. To unlock, press and hold the MODE button for 10 seconds.
- **ON1:** The display screen and control panel keys automatically lock after a certain period of inactivity, which can be set under *Personality > Display > Screen Saver Delay*. To unlock, press UP, DOWN, UP, DOWN, ENTER in that order.

BATTERY

This unit features a dedicated battery that can be used to power the screen display. This allows the user to configure the device's channel mode, DMX address, or any other screen-accessible features without needing to power on the device or even connect it to a power source. To activate the display on battery power, press and hold the MODE button for 3 seconds. **Please note that the battery is NOT user-accessible, and the user should NOT attempt to access or replace the battery, as doing so may void your manufacturer's warranty. If battery replacement is required, please contact ADJ service for assistance.**

SYSTEM MENU

| | | | | | |
|-------------------|------------------|---|--------------------------|--------------------------------------|---|
| DMX Settings | DMX Address | 001 - xxx | | | |
| | DMX Channel Mode | Basic 36 | | | |
| | | Standard 50 | | | |
| | | Extended 57 | | | |
| | No DMX Status | Hold Last | | | |
| | | Blackout | | | |
| Manual | | | | | |
| Internal Programs | | | | | |
| Personality | Prim/Sec Mode | Primary / Secondary | | | |
| | Select Signal | DMX or Wifly | | DMX has priority | |
| | | Wifly and DMX Out | | DMX XLR output shall send signal out | |
| | Wifly Settings | Wifly Enable | On / Off | | |
| | | Set Wifly Channel | 00 - 14 | | |
| | Status Settings | Pan Degree | 540 | | |
| | | Pan Invert | On / Off | | |
| | | Tilt Invert | On / Off | | |
| | | P/T Feedback | On / Off | | |
| | | P/T Speed | Speed 1 / Speed 2 | | |
| | | Hibernation | Off, 01m - 99m | | Default = 15m |
| | | Pump | On / Off | | Enable/disable oil vapor ventilation pump |
| | Fan Settings | Head Fan | Auto | | |
| | | | High | | |
| | | | Low | | |
| | | Base Fan | Auto | | |
| | | | High | | |
| | | | Low | | |
| | Zoom Speed | Standard / Fast | | | |
| | Dim Modes | Standard | | | |
| | | Stage | | | |
| | | TV | | | |
| | | Architectural | | | |
| | | Theatre | | | |
| | | Stage 2 | | | |
| | | Dim Speed | 0.1s - 10s | | |
| | LED Refresh Rate | 900-1500 Hz, 2500 Hz, 4000 Hz, 5000 Hz, 6000 Hz, 10 KHz, 15 KHz, 20 KHz, 25 KHz | | Default = 1200 Hz | |
| Dim Curve | Square | | | | |
| | Linear | | | | |
| | Inv. Squa. | | | | |
| | S. Curve | | | | |

CONTINUED ON NEXT PAGE

SYSTEM MENU

| | | | | | |
|------------------------------------|--------------|--------------------|--|------------------------|--|
| Personality (continued) | Reset Motors | Reset All Motors | Yes / No | | |
| | | Pan/Tilt Reset | Yes / No | | |
| | | ... | ... | | |
| | | Effect Reset | Yes / No | | |
| | Display | Intensity | 1- 10 | | |
| | | Display Invert | Yes / No | Display flip function | |
| | | Screen Saver Delay | Off - 10min | Default = 5 min | |
| | | Key Lock | Off | | |
| | | | On | | |
| | On1 | | | | |
| | Service | Passcode | Effect Adjust (Calibration) Passcode = 050 | Pan 000 - 255 | |
| | | | | Tilt 000 - 255 | |
| | | | | Cyan 000 - 255 | |
| | | | | Magenta 000 - 255 | |
| | | | | Yellow 000 - 255 | |
| | | | | CTO 000 - 255 | |
| | | | | ... | |
| Update Software | | | Off / On | | |
| Factory Restore Passcode = 011 | | | Off / On | | |
| Manual Control | Pan | 000 - 255 | | | |
| | Pan Fine | 000 - 255 | | | |
| | Tilt | 000 - 255 | | | |
| | Tilt Fine | 000 - 255 | | | |
| | ... | ... | | | |
| Internal Programs | Program 1 | Speed | 000 - 255 | | |
| | | Fade | 000 - 255 | | |
| | Program 2 | Speed | 000 - 255 | | |
| | | Fade | 000 - 255 | | |
| | ... | ... | ... | | |
| | Program 7 | Speed | 000 - 255 | | |
| | | Fade | 000 - 255 | | |

CONTINUED ON NEXT PAGE

SYSTEM MENU

| | | | | | | |
|--------------------|-------------------|-----------------|-----------------|----------------|--|--|
| Information | Fixture Life Time | Power On Time | xxxxxx Hours | | Total time fixture has been powered during its lifetime | |
| | | P-On Time-R | xxxxxx Hours | | Time fixture has been powered on since last reset | |
| | | P-On Time-Reset | Passcode = 050 | | Reset power on time | |
| | Total LED Time | LED On Time | xxxxxx Hours | | Total time LED has been powered on during fixture lifetime | |
| | | LED On Time-R | xxxxxx Hours | | Time LED has been powered on since last reset | |
| | | LED Hours Reset | Passcode = 050 | | Reset LED time | |
| | Fixture Temps | LEDs | Current | xxx F / xxx C | | |
| | | | Max Resettable | xxx F / xxx C | | |
| | | Base Temp | Current | xxx F / xxx C | | |
| | | | Max Resettable | xxx F / xxx C | | |
| | | Reset LED Temp | Yes / No | Passcode = 050 | | |
| | Reset Base Temp | Yes / No | Passcode = 050 | | | |
| | Fixture Humidity | Head | xxx% | | | |
| | | Base | xxx% | | | |
| | Fan Info (RPM) | LED Fan | xxxx RPM LED | | | |
| | | Base Fan | xxxx RPM | | | |
| | DMX Values | Pan | | | | |
| | | Pan Fine | | | | |
| | | ... | | | | |
| | Error Logs | xxxxx | | | Lists errors one by one | |
| Reset Error Log | | Yes / No | Passcode = 050 | | | |
| Software Version | xxx | | | | | |

DMX SETUP

DMX-512: DMX is short for Digital Multiplex. This is a universal protocol used as a form of communication between intelligent fixtures and controllers. A DMX controller sends DMX data instructions from the controller to the fixture. DMX data is sent as serial data that travels from fixture to fixture via the DATA “IN” and DATA “OUT” XLR terminals located on all DMX fixtures (most controllers only have a DATA “OUT” terminal).

DMX Linking: DMX is a language allowing all makes and models of different manufacturers to be linked together and operate from a single controller, as long as all fixtures and the controller are DMX compliant. To ensure proper DMX data transmission, try to use the shortest cable path possible when linking several DMX fixtures. The order in which fixtures are connected in a DMX line does not influence the DMX addressing. For example, a fixture assigned a DMX address of 1 may be placed anywhere in a DMX line: at the beginning, at the end, or anywhere in the middle. When a fixture is assigned a DMX address of 1, the DMX controller knows to send DATA assigned to address 1 to that unit, no matter where it is located in the DMX chain.

Data Cable (DMX Cable) Requirements (For DMX Operation): This device can be controlled via DMX-512 protocol, and features multiple DMX channel modes. Your unit and your DMX controller require a 3-pin or 5-pin XLR connector for data input and data output. If you are making your own cables, be sure to use standard 110-120 Ohm shielded cable (This cable may be purchased at almost all professional lighting stores). Your cables should be made with a male XLR connector at one end and a female XLR connector at the other. Also remember that DMX cable must be daisy chained and cannot be split.

Special Note: Line Termination. When longer runs of cable are used, you may need to use a terminator on the last unit to avoid erratic behavior. A terminator is a 110-120 ohm 1/4 watt resistor which is connected between pins 2 and 3 of a male XLR connector (DATA + and DATA -). This unit is inserted in the female XLR connector of the last unit in your daisy chain to terminate the line. Using a cable terminator (ADJ part number Z-DMX/T) will decrease the chances of erratic behavior.

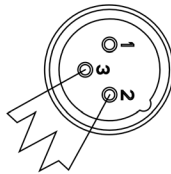
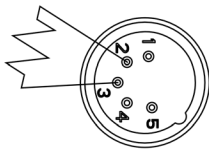

A DMX512 terminator reduces signal errors, avoiding most signal reflection interference. Connect PIN 2 (DMX-) and PIN 3 (DMX+) of the last fixture in series with a 120 Ohm, 1/4 W Resistor to terminate the DMX512.

DMX SETUP

DMX ADDRESSING

All fixtures should be given a DMX starting address when operating with a DMX controller, in order to ensure that the correct fixture responds to the correct control signal. This digital starting address is the channel number from which the fixture starts to “listen” to the digital control signal sent out from the DMX controller. The starting DMX address is configured by setting the correct DMX address on the control panel display on the fixture.

You can set the same starting address for multiple fixtures, or set different addresses for each individual fixture. Setting multiple fixtures to the same DMX address will cause all those fixtures to react in the same way. In this case, please note that changing the settings of one channel will affect all the fixtures simultaneously.

If you set each fixture to a different DMX address, each unit will start to “listen” to the channel number you have set, based on the quantity of DMX channels of each fixture. That means changing the settings of one channel will only affect the selected fixture.

As an example, when operating this device in 36 channel mode, you should set the starting DMX address of the first unit to 1, the second unit to 37 (1 + 36), the third unit to 73 (1 + 36 + 36), and so on. (See the chart below for more details.)

| Channel Mode | Unit 1 Address | Unit 2 Address | Unit 3 Address | Unit 4 Address |
|--------------|----------------|----------------|----------------|----------------|
| 36 Channels | 1 | 37 | 73 | 109 |
| 50 Channels | 1 | 51 | 101 | 151 |
| 57 Channels | 1 | 58 | 115 | 172 |

DMX TRAITS

| CHANNEL | | | DMX VALUE | FUNCTION |
|-----------|--|-------|-----------|---|
| 36 CH | 50 CH | 57 CH | | |
| 1 | 1 | 1 | 000 - 255 | Pan Movement , 540 |
| | 2 | 2 | 000 - 255 | Pan Fine |
| 2 | 3 | 3 | 000 - 255 | Tilt Movement , 270 |
| | 4 | 4 | 000 - 255 | Tilt Fine |
| 3 | 5 | 5 | 000 - 255 | Cyan , 0% to 100% |
| | | 6 | 000 - 255 | Cyan Fine , 0% to 100% |
| 4 | 6 | 7 | 000 - 255 | Magenta , 0% to 100% |
| | | 8 | 000 - 255 | Magenta Fine , 0% to 100% |
| 5 | 7 | 9 | 000 - 255 | Yellow , 0% to 100% |
| | | 10 | 000 - 255 | Yellow Fine , 0% to 100% |
| 6 | 8 | 11 | 000 - 255 | CTO , 0 % to 100% |
| | | 12 | 000 - 255 | CTO Fine , 0% to 100% |
| 7 | 9 | 13 | | White Color Temperature Presets |
| | | | 000 - 023 | Open |
| | | | 024 - 076 | White Color Temperature Presets, see White Color Temperature Chart section of this manual |
| | | | 077 - 255 | 8000K |
| 8 | 10 | 14 | | Color Wheel |
| | | | 000 - 004 | Open |
| | | | 005 - 017 | Open / Red |
| | | | 018 - 030 | Red |
| | | | 031 - 043 | Red / Medium Blue |
| | | | 044 - 056 | Medium Blue |
| | | | 057 - 069 | Medium Blue / Green |
| | | | 070 - 082 | Green |
| | | | 083 - 095 | Green / Amber |
| | | | 096 - 108 | Amber |
| | | | 109 - 121 | Amber / Orange |
| | | | 122 - 134 | Orange |
| | | | 135 - 147 | Orange / High CRI Filter |
| | | | 148 - 160 | High CRI Filter |
| | | | 161 - 173 | High CRI Filter / CTB |
| | | | 174 - 186 | CTB |
| | | | 187 - 199 | CTB / Open |
| 200 - 226 | Clockwise Color Wheel Rotation, fast to slow | | | |
| 227 - 228 | No Rotation | | | |
| 229 - 255 | Counter-Clockwise Color Wheel Rotation, slow to fast | | | |
| | 11 | 15 | | Color Macros |
| | | | 000 - 031 | Off |
| | | | 032 - 039 | Macro1 |
| | | | 040 - 047 | Macro2 |

CONTINUED ON NEXT PAGE

DMX TRAITS

| CHANNEL | | | DMX VALUE | FUNCTION |
|-----------|------------|-------|-----------|---------------------------------|
| 36 CH | 50 CH | 57 CH | | |
| | 11 | 15 | | Color Macros (continued) |
| | | | 048 - 055 | Macro3 |
| | | | 056 - 063 | Macro4 |
| | | | 064 - 071 | Macro5 |
| | | | 072 - 079 | Macro6 |
| | | | 080 - 087 | Macro7 |
| | | | 088 - 095 | Macro8 |
| | | | 096 - 103 | Macro9 |
| | | | 104 - 111 | Macro10 |
| | | | 112 - 119 | Macro11 |
| | | | 120 - 127 | Macro12 |
| | | | 128 - 135 | Macro13 |
| | | | 136 - 143 | Macro14 |
| | | | 144 - 151 | Macro15 |
| | | | 152 - 159 | Macro16 |
| | | | 160 - 167 | Macro17 |
| | | | 168 - 175 | Macro18 |
| | | | 176 - 183 | Macro19 |
| | | | 184 - 191 | Macro20 |
| | | | 192 - 199 | Macro21 |
| | | | 200 - 207 | Macro22 |
| | | | 208 - 215 | Macro23 |
| | | | 216 - 223 | Macro24 |
| | | | 224 - 231 | Macro25 |
| 232 - 239 | Macro26 | | | |
| 240 - 247 | Macro27 | | | |
| 248 - 255 | Random CMY | | | |
| 9 | 12 | 16 | | Gobo Wheel 1 |
| | | | 000 - 009 | Open |
| | | | 010 - 019 | Gobo 1 |
| | | | 020 - 029 | Gobo 2 |
| | | | 030 - 039 | Gobo 3 |
| | | | 040 - 049 | Gobo 4 |
| | | | 050 - 059 | Gobo 5 |
| | | | 060 - 069 | Gobo 6 |
| | | | 070 - 079 | Gobo 7 |
| | | | 080 - 094 | Gobo 1 Shake, slow to fast |
| | | | 095 - 109 | Gobo 2 Shake, slow to fast |
| | | | 110 - 124 | Gobo 3 Shake, slow to fast |
| | | | 125 - 139 | Gobo 4 Shake, slow to fast |
| | | | 140 - 154 | Gobo 5 Shake, slow to fast |

CONTINUED ON NEXT PAGE

DMX TRAITS

| CHANNEL | | | DMX VALUE | FUNCTION |
|-----------|---|-------|-----------|---|
| 36 CH | 50 CH | 57 CH | | |
| 9 | 12 | 16 | | <i>Gobo Wheel 1 (continued)</i> |
| | | | 155 - 169 | Gobo 6 Shake, slow to fast |
| | | | 170 - 189 | Gobo 7 Shake, slow to fast |
| | | | 190 - 221 | Clockwise Gobo Wheel Rotation, fast to slow |
| | | | 222 - 223 | No Rotation |
| | | | 224 - 255 | Counter-Clockwise Gobo Wheel Rotation, slow to fast |
| 10 | 13 | 17 | | <i>Gobo 1 Rotation</i> |
| | | | 000 - 005 | Gobo 1 Rotation Off |
| | | | 006 - 128 | Gobo Index, 0°...540° |
| | | | 129 - 191 | Clockwise Gobo Rotation, fast to slow |
| | | | 192 | No Rotation |
| | | | 193 - 255 | Counter-Clockwise Gobo Rotation, slow to fast |
| | | 18 | 000 - 255 | <i>Gobo 1 Rotation Fine</i> |
| 11 | 14 | 19 | | <i>Gobo Wheel 2</i> |
| | | | 000 - 005 | Open |
| | | | 006 - 014 | Gobo 1 |
| | | | 015 - 023 | Gobo 2 |
| | | | 024 - 032 | Gobo 3 |
| | | | 033 - 041 | Gobo 4 |
| | | | 042 - 050 | Gobo 5 |
| | | | 051 - 059 | Gobo 6 |
| | | | 060 - 068 | Gobo 7 |
| | | | 069 - 077 | Gobo 8 |
| | | | 078 - 091 | Gobo 1 Shake, slow to fast |
| | | | 092 - 105 | Gobo 2 Shake, slow to fast |
| | | | 106 - 119 | Gobo 3 Shake, slow to fast |
| | | | 120 - 133 | Gobo 4 Shake, slow to fast |
| | | | 134 - 147 | Gobo 5 Shake, slow to fast |
| | | | 148 - 161 | Gobo 6 Shake, slow to fast |
| | | | 162 - 175 | Gobo 7 Shake, slow to fast |
| | | | 176 - 189 | Gobo 8 Shake, slow to fast |
| | | | 190 - 221 | Clockwise Gobo Wheel Rotation, fast to slow |
| | | | 222 - 223 | No Rotation |
| 224 - 255 | Counter-Clockwise Gobo Wheel Rotation, slow to fast | | | |

CONTINUED ON NEXT PAGE

DMX TRAITS

| CHANNEL | | | DMX VALUE | FUNCTION |
|-----------|---------|-----------|--|--|
| 36 CH | 50 CH | 57 CH | | |
| 12 | 15 | 20 | | Shutter |
| | | | 000 - 031 | Shutter Closed |
| | | | 032 - 063 | Shutter Open |
| | | | 064 - 095 | Strobe, slow to fast |
| | | | 096 - 127 | Shutter Open |
| | | | 128 - 159 | Pulse Effect, slow to fast |
| | | | 160 - 191 | Shutter Open |
| | | | 192 - 223 | Random Strobe, slow to fast |
| | | 224 - 255 | Shutter Open | |
| 13 | 16 | 21 | 000 - 255 | Dimmer Intensity , 0% to 100% |
| | 17 | 22 | 000 - 255 | Dimmer Intensity Fine |
| 14 | 18 | 23 | | Prisms and Prism/Gobo Macros |
| | | | 000 - 005 | No Prism (Open) |
| | | | 006 - 066 | Prism 1 (6 Linear Prism) |
| | | | 067 - 127 | Prism 2 (4 Facet Prism) |
| | | | 128 - 135 | Macro1 |
| | | | 136 - 143 | Macro2 |
| | | | 144 - 151 | Macro3 |
| | | | 152 - 159 | Macro4 |
| | | | 160 - 167 | Macro5 |
| | | | 168 - 175 | Macro6 |
| | | | 176 - 183 | Macro7 |
| | | | 184 - 191 | Macro8 |
| | | | 192 - 199 | Macro9 |
| | | | 200 - 207 | Macro10 |
| | | | 208 - 215 | Macro11 |
| | | | 216 - 223 | Macro12 |
| | | | 224 - 231 | Macro13 |
| 232 - 239 | Macro14 | | | |
| 240 - 247 | Macro15 | | | |
| 248 - 255 | Macro16 | | | |
| 15 | 19 | 24 | | Prism Rotation |
| | | | 000 - 005 | Prism Rotation Off |
| | | | 006 - 128 | Prism Indexing, 0°...540° |
| | | | 129 - 191 | Clockwise Prism Rotation, fast to slow |
| | | | 192 | No Rotation |
| | | 193 - 255 | Counter-Clockwise Prism Rotation, slow to fast | |
| 16 | 20 | 25 | 000 - 255 | Focus , 0% to 100% |
| | | 26 | 000 - 255 | Focus Fine , 0% to 100% |
| 17 | 21 | 27 | 000 - 255 | Zoom , narrow to wide |
| | | 28 | 000 - 255 | Zoom Fine , narrow to wide |

CONTINUED ON NEXT PAGE

DMX TRAITS

| CHANNEL | | | DMX VALUE | FUNCTION |
|---------|-------|-----------|--|---|
| 36 CH | 50 CH | 57 CH | | |
| 18 | 22 | 29 | | <i>Iris</i> |
| | | | 000 - 225 | Open to Close |
| | | | 226 - 235 | Pulse Up, slow to fast |
| | | | 236 - 245 | Pulse Down, slow to fast |
| | | | 246 - 255 | Random Effect, slow to fast |
| 19 | 23 | 30 | 000 - 255 | <i>Medium Frost</i> , 0% to 100% |
| 20 | 24 | 31 | 000 - 255 | <i>Heavy Frost</i> , 0% to 100% |
| 21 | 25 | 32 | | <i>Animation</i> |
| | | | 000 - 005 | Animation Rotation Off |
| | | | 006 - 128 | Animation Index, 0°...540° |
| | | | 129 - 191 | Clockwise Animation Rotation, fast to slow |
| | | | 192 | No Rotation |
| | | 193 - 255 | Counter-Clockwise Animation Rotation, slow to fast | |
| 22 | 26 | 33 | 000 - 255 | <i>Blade 1A</i> , 0% to 100% |
| | 27 | 34 | 000 - 255 | <i>Blade 1A Fine</i> , 0% to 100% |
| 23 | 28 | 35 | 000 - 255 | <i>Blade 1B</i> , 0% to 100% |
| | 29 | 36 | 000 - 255 | <i>Blade 1B Fine</i> , 0% to 100% |
| 24 | 30 | 37 | 000 - 255 | <i>Blade 2A</i> , 0% to 100% |
| | 31 | 38 | 000 - 255 | <i>Blade 2A Fine</i> , 0% to 100% |
| 25 | 32 | 39 | 000 - 255 | <i>Blade 2B</i> , 0% to 100% |
| | 33 | 40 | 000 - 255 | <i>Blade 2B Fine</i> , 0% to 100% |
| 26 | 34 | 41 | 000 - 255 | <i>Blade 3A</i> , 0% to 100% |
| | 35 | 42 | 000 - 255 | <i>Blade 3A Fine</i> , 0% to 100% |
| 27 | 36 | 43 | 000 - 255 | <i>Blade 3B</i> , 0% to 100% |
| | 37 | 44 | 000 - 255 | <i>Blade 3B Fine</i> , 0% to 100% |
| 28 | 38 | 45 | 000 - 255 | <i>Blade 4A</i> , 0% to 100% |
| | 39 | 46 | 000 - 255 | <i>Blade 4A Fine</i> , 0% to 100% |
| 29 | 40 | 47 | 000 - 255 | <i>Blade 4B</i> , 0% to 100% |
| | 41 | 48 | 000 - 255 | <i>Blade 4B Fine</i> , 0% to 100% |
| 30 | 42 | 49 | 000 - 255 | <i>Frame Rotation</i> , 0° to 120° |
| | 43 | 50 | 000 - 255 | <i>Frame Rotation Fine</i> , 0% to 100% |
| 31 | 44 | 51 | 000 - 255 | <i>Frame Speed</i> , max to min |
| 32 | 45 | 52 | | <i>Frame Macros</i> , refer to <i>Frame Macros Chart</i> section of this manual |
| | | | 000 - 007 | Off |
| | | | 008 - 015 | Macro 1 |
| | | | 016 - 023 | Macro 2 |
| | | | 024 - 031 | Macro 3 |
| | | | 032 - 039 | Macro 4 |
| | | | 040 - 047 | Macro 5 |
| | | | 048 - 055 | Macro 6 |
| | | | 056 - 063 | Macro 7 |

CONTINUED ON NEXT PAGE

DMX TRAITS

| CHANNEL | | | DMX VALUE | FUNCTION |
|-----------|-------------------------|-----------|-------------|--|
| 36 CH | 50 CH | 57 CH | | |
| 32 | 45 | 52 | | <i>Frame Macros (continued)</i> |
| | | | 064 - 071 | Macro 8 |
| | | | 072 - 079 | Macro 9 |
| | | | 080 - 087 | Macro 10 |
| | | | 088 - 095 | Macro 11 |
| | | | 096 - 103 | Macro 12 |
| | | | 104 - 111 | Macro 13 |
| | | | 112 - 119 | Macro 14 |
| | | | 120 - 127 | Macro 15 |
| | | | 128 - 135 | Macro 16 |
| | | | 136 - 143 | Macro 17 |
| | | | 144 - 151 | Macro 18 |
| | | | 152 - 159 | Macro 19 |
| | | | 160 - 167 | Macro 20 |
| | | | 168 - 175 | Macro 21 |
| | | | 176 - 183 | Macro 22 |
| | | | 184 - 191 | Macro 23 |
| | | | 192 - 199 | Macro 24 |
| | | | 200 - 207 | Macro 25 |
| | | | 208 - 215 | Macro 26 |
| 216 - 223 | Macro 27 | | | |
| 224 - 231 | Macro 28 | | | |
| 232 - 239 | Macro 29 | | | |
| 240 - 247 | Macro 30 | | | |
| 248 - 255 | Macro 31 | | | |
| 33 | 46 | 53 | | <i>Dimmer Mode</i> |
| | | | 000 - 020 | Default to Unit Setting |
| | | | 021 - 040 | Standard |
| | | | 041 - 060 | Stage |
| | | | 061 - 080 | TV |
| | | | 081 - 100 | Architectural |
| | | | 101 - 120 | Theater |
| | | | 121 - 140 | Stage 2 |
| | | | 141 - 160 | Dim Speed, fast to slow (0.1s to 10s) |
| 161 - 255 | Default to Unit Setting | | | |
| | 47 | 54 | | <i>Dim Curves</i> |
| | | | 000 - 020 | Square |
| | | | 021 - 040 | Linear |
| | | | 041 - 060 | Inv. Squa. |
| | | | 061 - 080 | S. Curve |
| | | 081 - 255 | No Function | |

CONTINUED ON NEXT PAGE

DMX TRAITS

| CHANNEL | | | DMX VALUE | FUNCTION | | |
|---------|-------|-------|-----------|---|-------------------------------|--------|
| 36 CH | 50 CH | 57 CH | | | | |
| 34 | 48 | 55 | 000 - 255 | CMY & Color Macro Speed , max to min | | |
| 35 | 49 | 56 | | Pan/Tilt Speed | | |
| | | | 000 - 225 | Pan/Tilt, fast to slow | | |
| | | | 226 - 235 | Blackout by movement | | |
| | | | 236 - 245 | Blackout by all wheel changing | | |
| | | | 246 - 255 | No function | | |
| 36 | 50 | 57 | | Special Functions | | |
| | | | 000 - 039 | Default LED Refresh Rate (1200 Hz) | | |
| | | | 040 - 049 | Fan Control, Low (Hold 3s) | | |
| | | | 050 - 059 | Fan Control, High (Hold 3s) | | |
| | | | 060 - 069 | Fan Control, Auto (Default, Hold 3s) | | |
| | | | 070 - 074 | All Motor Reset (Hold 3s) | | |
| | | | 075 - 079 | Pan/Tilt Reset (Hold 3s) | | |
| | | | 080 - 084 | Color Reset (Hold 3s) | | |
| | | | 085 - 089 | Gobo Reset (Hold 3s) | | |
| | | | 090 - 094 | Focus and Zoom Reset (Hold 3s) | | |
| | | | 095 - 099 | Shutter Reset (Hold 3s) | | |
| | | | 100 - 104 | Framing Reset (Hold 3s) | | |
| | | | 105 - 109 | Other Motors Reset (Hold 3s) | | |
| | | | 110 - 114 | Enable Zoom Speed Fast (Hold 3s) | | |
| | | | 115 - 119 | Disable Zoom Speed Fast (Hold 5s) | | |
| | | | 120 - 124 | Pump On | | |
| | | | 125 - 129 | Pump Off | | |
| | | | 130 - 148 | No Function | | |
| | | | 149 - 150 | Wifly On (Default, Hold 3s) | | |
| | | | 151 - 152 | Wifly Off (Hold 5s) | | |
| | | | 153 - 154 | Hibernation Enable (Hold 3s) | | |
| | | | 155 - 156 | Hibernation Off (Hold 5s) | | |
| | | | 157 - 158 | Display Backlight On (Hold 3s) | | |
| | | | 159 - 160 | Display Backlight Off (Hold 5s) | | |
| | | | 161 - 162 | Pan/Tilt Speed 1 (Default, Hold 5s) | | |
| | | | 163 - 164 | Pan/Tilt Speed 2 (Hold 5s) | | |
| | | | 165 - 166 | Invert Pan On (Hold 3s) | | |
| | | | 167 - 168 | Invert Pan Off (Hold 5s) | | |
| | | | 169 - 170 | Invert Tilt On (Hold 3s) | | |
| | | | 171 - 172 | Invert Tilt Off (Hold 5s) | | |
| | | | | | Refresh Rate (Hold 1s) | |
| | | | | | 173 | 900 Hz |
| | | | | | 174 | 910 Hz |
| | | 175 | 920 Hz | | | |
| | | 176 | 930 Hz | | | |

CONTINUED ON NEXT PAGE

DMX TRAITS

| CHANNEL | | | DMX VALUE | FUNCTION |
|---------|---------|-------|-----------|---------------------------------|
| 36 CH | 50 CH | 57 CH | | |
| 36 | 50 | 57 | | <i>Refresh Rate (continued)</i> |
| | | | 177 | 940 Hz |
| | | | 178 | 950 Hz |
| | | | 179 | 960 Hz |
| | | | 180 | 970 Hz |
| | | | 181 | 980 Hz |
| | | | 182 | 990 Hz |
| | | | 183 | 1000 Hz |
| | | | 184 | 1010 Hz |
| | | | 185 | 1020 Hz |
| | | | 186 | 1030 Hz |
| | | | 187 | 1040 Hz |
| | | | 188 | 1050 Hz |
| | | | 189 | 1060 Hz |
| | | | 190 | 1070 Hz |
| | | | 191 | 1080 Hz |
| | | | 192 | 1090 Hz |
| | | | 193 | 1100 Hz |
| | | | 194 | 1110 Hz |
| | | | 195 | 1120 Hz |
| | | | 196 | 1130 Hz |
| | | | 197 | 1140 Hz |
| | | | 198 | 1150 Hz |
| | | | 199 | 1160 Hz |
| | | | 200 | 1170 Hz |
| | | | 201 | 1180 Hz |
| 202 | 1190 Hz | | | |
| 203 | 1210 Hz | | | |
| 204 | 1220 Hz | | | |
| 205 | 1230 Hz | | | |
| 206 | 1240 Hz | | | |
| 207 | 1250 Hz | | | |
| 208 | 1260 Hz | | | |
| 209 | 1270 Hz | | | |
| 210 | 1280 Hz | | | |
| 211 | 1290 Hz | | | |
| 212 | 1300 Hz | | | |
| 213 | 1310 Hz | | | |
| 214 | 1320 Hz | | | |
| 215 | 1330 Hz | | | |
| 216 | 1340 Hz | | | |

CONTINUED ON NEXT PAGE

DMX TRAITS

| CHANNEL | | | DMX VALUE | FUNCTION |
|-----------|---|-------|-----------|---|
| 36 CH | 50 CH | 57 CH | | |
| 36 | 50 | 57 | | <i>Refresh Rate (continued)</i> |
| | | | 217 | 1350 Hz |
| | | | 218 | 1360 Hz |
| | | | 219 | 1370 Hz |
| | | | 220 | 1380 Hz |
| | | | 221 | 1390 Hz |
| | | | 222 | 1400 Hz |
| | | | 223 | 1410 Hz |
| | | | 224 | 1420 Hz |
| | | | 225 | 1430 Hz |
| | | | 226 | 1440 Hz |
| | | | 227 | 1450 Hz |
| | | | 228 | 1460 Hz |
| | | | 229 | 1470 Hz |
| | | | 230 | 1480 Hz |
| | | | 231 | 1490 Hz |
| | | | 232 | 1500 Hz |
| | | | 233 | 2500 Hz |
| | | | 234 | 4000 Hz |
| | | | 235 | 5000 Hz |
| | | | 236 | 6000 Hz |
| | | | 237 | 10,000 Hz |
| | | | 238 | 15,000 Hz |
| | | | 239 | 20,000 Hz |
| | | | 240 | 25,000 Hz |
| | | | 241 | Internal Program 1 (Scenes 1-8) (Hold 3s) |
| | | | 242 | Internal Program 2 (Scenes 9-16) (Hold 3s) |
| | | | 243 | Internal Program 3 (Scenes 17-24) (Hold 3s) |
| 244 | Internal Program 4 (Scenes 25-32) (Hold 3s) | | | |
| 245 | Internal Program 5 (Scenes 33-40) (Hold 3s) | | | |
| 246 | Internal Program 6 (Scenes 41-48) (Hold 3s) | | | |
| 247 | Internal Program 7 (Scenes 49-56) (Hold 3s) | | | |
| 248 - 255 | No function | | | |

COLOR WHEEL

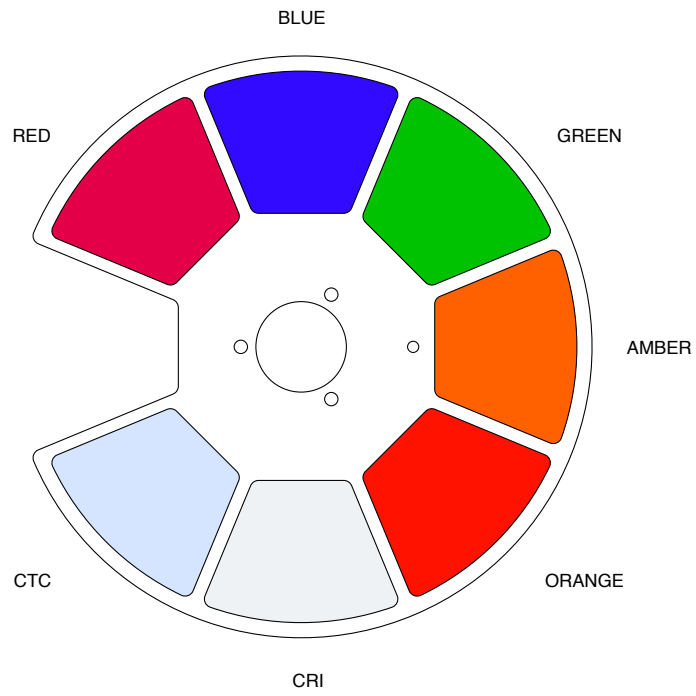

ANIMATION WHEEL

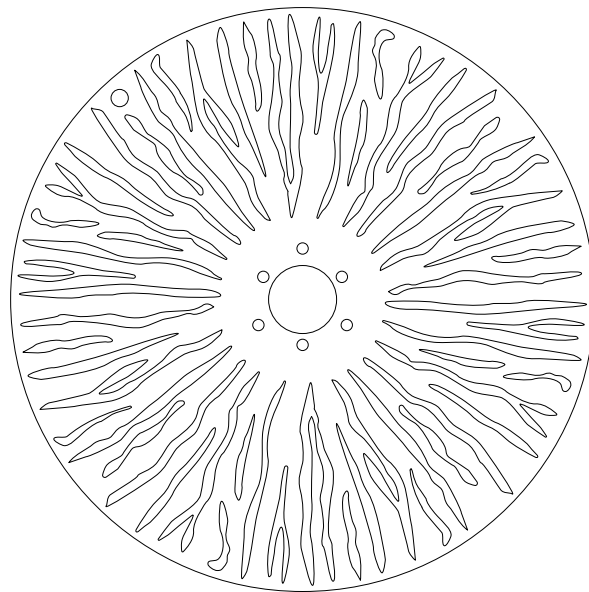

WHITE COLOR TEMPERATURE CHART

| DMX VALUES | COLOR TEMPERATURE |
|------------|-------------------|
| 024 | 2700 |
| 025 | 2800 |
| 026 | 2900 |
| 027 | 3000 |
| 028 | 3100 |
| 029 | 3200 |
| 030 | 3300 |
| 031 | 3400 |
| 032 | 3500 |
| 033 | 3600 |
| 034 | 3700 |
| 035 | 3800 |
| 036 | 3900 |
| 037 | 4000 |
| 038 | 4100 |
| 039 | 4200 |
| 040 | 4300 |
| 041 | 4400 |
| 042 | 4500 |
| 043 | 4600 |
| 044 | 4700 |
| 045 | 4800 |
| 046 | 4900 |
| 047 | 5000 |
| 048 | 5100 |
| 049 | 5200 |
| 050 | 5300 |

| DMX VALUES | COLOR TEMPERATURE |
|------------|-------------------|
| 051 | 5400 |
| 052 | 5500 |
| 053 | 5600 |
| 054 | 5700 |
| 055 | 5800 |
| 056 | 5900 |
| 057 | 6000 |
| 058 | 6100 |
| 059 | 6200 |
| 060 | 6300 |
| 061 | 6400 |
| 062 | 6500 |
| 063 | 6600 |
| 064 | 6700 |
| 065 | 6800 |
| 066 | 6900 |
| 067 | 7000 |
| 068 | 7100 |
| 069 | 7200 |
| 070 | 7300 |
| 071 | 7400 |
| 072 | 7500 |
| 073 | 7600 |
| 074 | 7700 |
| 075 | 7800 |
| 076 | 7900 |

FRAME MACROS CHART

| MACRO NUMBER | FRAME BLADE 1A | FRAME BLADE 1B | FRAME BLADE 2A | FRAME BLADE 2B | FRAME BLADE 3A | FRAME BLADE 3B | FRAME BLADE 4A | FRAME BLADE 4B |
|--------------|----------------|----------------|----------------|----------------|----------------|----------------|----------------|----------------|
| 1 | 150 | 0 | 150 | 0 | 150 | 0 | 150 | 0 |
| 2 | 138 | 116 | 126 | 0 | 162 | 206 | 88 | 146 |
| 3 | 146 | 0 | 208 | 70 | 166 | 0 | 162 | 168 |
| 4 | 220 | 0 | 122 | 0 | 166 | 0 | 114 | 64 |
| 5 | 0 | 104 | 0 | 124 | 0 | 162 | 64 | 132 |
| 6 | 88 | 74 | 132 | 240 | 84 | 144 | 114 | 60 |
| 7 | 144 | 74 | 0 | 255 | 10 | 108 | 48 | 116 |
| 8 | 138 | 116 | 198 | 0 | 162 | 106 | 112 | 78 |
| 9 | 96 | 100 | 0 | 130 | 162 | 0 | 0 | 172 |
| 10 | 138 | 216 | 134 | 0 | 0 | 206 | 88 | 146 |
| 11 | 88 | 94 | 0 | 244 | 46 | 112 | 114 | 44 |
| 12 | 138 | 216 | 140 | 0 | 0 | 206 | 0 | 0 |
| 13 | 124 | 62 | 216 | 0 | 108 | 206 | 126 | 2 |
| 14 | 152 | 118 | 128 | 106 | 136 | 102 | 68 | 114 |
| 15 | 124 | 54 | 0 | 154 | 16 | 118 | 126 | 206 |
| 16 | 0 | 214 | 2 | 146 | 0 | 124 | 0 | 128 |
| 17 | 144 | 74 | 0 | 152 | 10 | 240 | 138 | 74 |
| 18 | 102 | 120 | 56 | 202 | 30 | 102 | 152 | 40 |
| 19 | 174 | 104 | 100 | 124 | 194 | 152 | 64 | 132 |
| 20 | 88 | 74 | 132 | 240 | 84 | 102 | 114 | 172 |
| 21 | 86 | 112 | 168 | 0 | 228 | 26 | 122 | 64 |
| 22 | 146 | 0 | 208 | 70 | 166 | 0 | 162 | 0 |
| 23 | 138 | 116 | 126 | 0 | 162 | 206 | 112 | 78 |
| 24 | 150 | 154 | 150 | 0 | 150 | 0 | 150 | 86 |
| 25 | 122 | 0 | 0 | 196 | 150 | 0 | 150 | 86 |
| 26 | 182 | 0 | 98 | 124 | 162 | 64 | 0 | 168 |
| 27 | 210 | 0 | 120 | 0 | 166 | 0 | 162 | 0 |
| 28 | 88 | 92 | 150 | 0 | 228 | 144 | 114 | 0 |
| 29 | 122 | 0 | 0 | 130 | 162 | 0 | 220 | 86 |
| 30 | 124 | 54 | 216 | 154 | 16 | 118 | 126 | 2 |
| 31 | 138 | 116 | 198 | 142 | 0 | 160 | 138 | 80 |

DIM SPEEDS

| DMX VALUE | DELAY TIME |
|-----------|------------|
| 141 | 0.1 s |
| 142 | 0.2 s |
| 143 | 0.3 s |
| 144 | 0.4 s |
| 145 | 0.5 s |
| 146 | 0.6 s |
| 147 | 0.7 s |
| 148 | 0.8 s |
| 149 | 0.9 s |
| 150 | 1.0 s |
| 151 | 1.5 s |
| 152 | 2.0 s |
| 153 | 3.0 s |
| 154 | 4.0 s |
| 155 | 5.0 s |
| 156 | 6.0 s |
| 157 | 7.0 s |
| 158 | 8.0 s |
| 159 | 9.0 s |
| 160 | 10.0 s |

DIMMER MODES

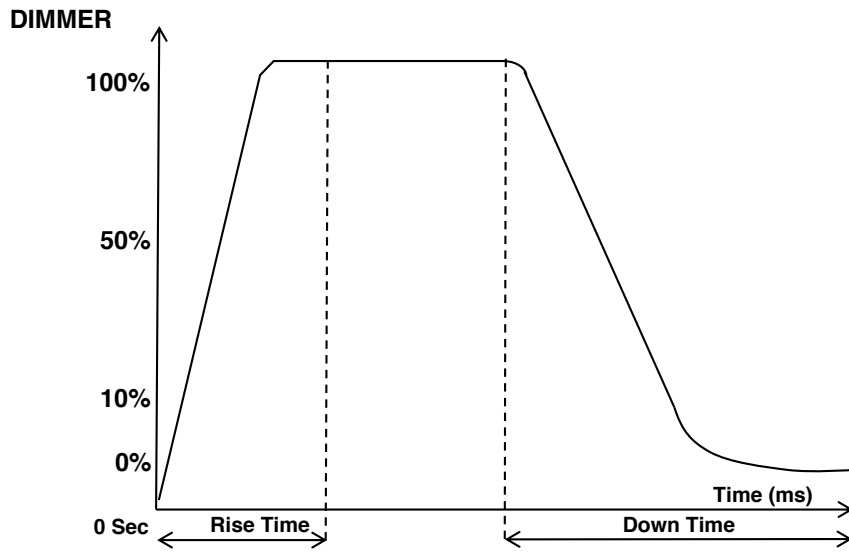

| Dimming Curve Ramp Effect | 0 sec Fade Time | | 1 sec Fade Time | |
|---------------------------|-----------------|----------------|-----------------|----------------|
| | Rise Time (ms) | Down Time (ms) | Rise Time (ms) | Down Time (ms) |
| Standard (default) | 0 | 0 | 0 | 0 |
| Stage | 780 | 1100 | 1540 | 1660 |
| TV | 1180 | 1520 | 1860 | 1940 |
| Architectural | 1380 | 1730 | 2040 | 2120 |
| Theatre | 1580 | 1940 | 2230 | 2280 |
| Stage 2 | 0 | 1100 | 0 | 1660 |

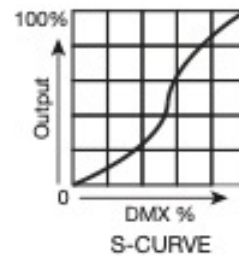
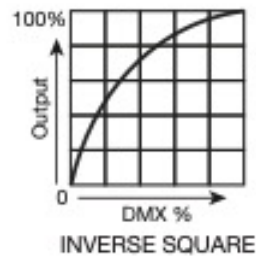
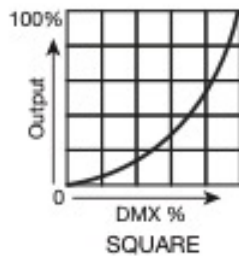
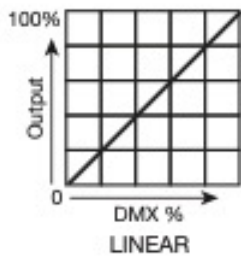

CLEANING AND MAINTENANCE

DISCONNECT POWER BEFORE PERFORMING ANY MAINTENANCE!

CLEANING

Frequent cleaning is recommended to ensure proper function, optimized light output, and an extended life. The frequency of cleaning depends on the environment in which the fixture operates: damp, smoky, or particularly dirty environments can cause greater accumulation of dirt on the fixture's optics. Clean the external lens surface periodically with a soft cloth to avoid dirt/debris accumulation.

NEVER use alcohol, solvents, or ammonia-based cleaners.

MAINTENANCE

Regular inspections are recommended to ensure proper function and extended life. There are no user serviceable parts inside this fixture. Please refer all other service issues to an authorized ADJ service technician. Should you need any spare parts, please order genuine parts from your local ADJ dealer.

Please refer to the following points during routine inspections:

- A detailed electrical check by an approved electrical engineer every three months, to make sure the circuit contacts are in good condition and prevent overheating.
- Be sure all screws and fasteners are securely tightened at all times. Loose screws may fall out during normal operation, resulting in damage or injury as larger parts could fall.
- Check for any deformations on the housing, color lenses, rigging hardware, and rigging points (ceiling, suspension, trussing). Deformations in the housing could allow for dust or liquids to enter into the fixture. Damaged rigging points or unsecured rigging could cause fixture to fall and seriously injure a person(s).
- Electric power supply cables must not show any damage, material fatigue, or sediments.

NEVER remove the ground prong from the power cable.

FIXTURE DISASSEMBLY

The following points should be observed after performing any maintenance procedure that requires disassembly of the unit:

- After the unit has been reassembled, open the valve, and allow the light to run for approximately 2 hours in order to dry out any moisture that has been trapped inside the fixture. The process should continue until indicated humidity drops below 15% for the head and 30% for the base.
- Once this has been achieved, the light can be switched off, but the unit should remain connected to power so that the cooling fan can cool down the unit. Please note that allowing cool down time should ALWAYS be done after lamp operation.
- Some units may require partial disassembly in order to gain access to the valve. Please contact ADJ service for information regarding the location and access procedure for the valve on your specific unit model.

CLEANING AND MAINTENANCE

PUMP FUNCTION

Certain mechanisms within this fixture, such as the effects wheels and the framing mechanism, emit small amounts of oil vapor, which can accumulate on the lens and result in reduced light output. To counteract this issue, this fixture features an air pump installed in the arm, which serves to ventilate the air inside the fixture head in order to remove this oil vapor. In particular, it is recommended to run this pump following maintenance or repair procedures of mechanisms inside the head, as these procedures can result in increased emission of oil vapor. Refer to the **System Menu** section of this manual for instructions on how to activate this pump.

SOFTWARE UPDATES

For software updates, please contact ADJ service to obtain a software uploader and detailed instructions. Refer to the **Introduction** section of this manual for contact information.

TORQUE SETTINGS FOR SCREWS

ALL SCREWS MUST BE TIGHTENED WITH A TORQUE DRIVER. All screws are Allen head screws. Please refer to the table and diagram below for screw locations, quantity, and torque settings.

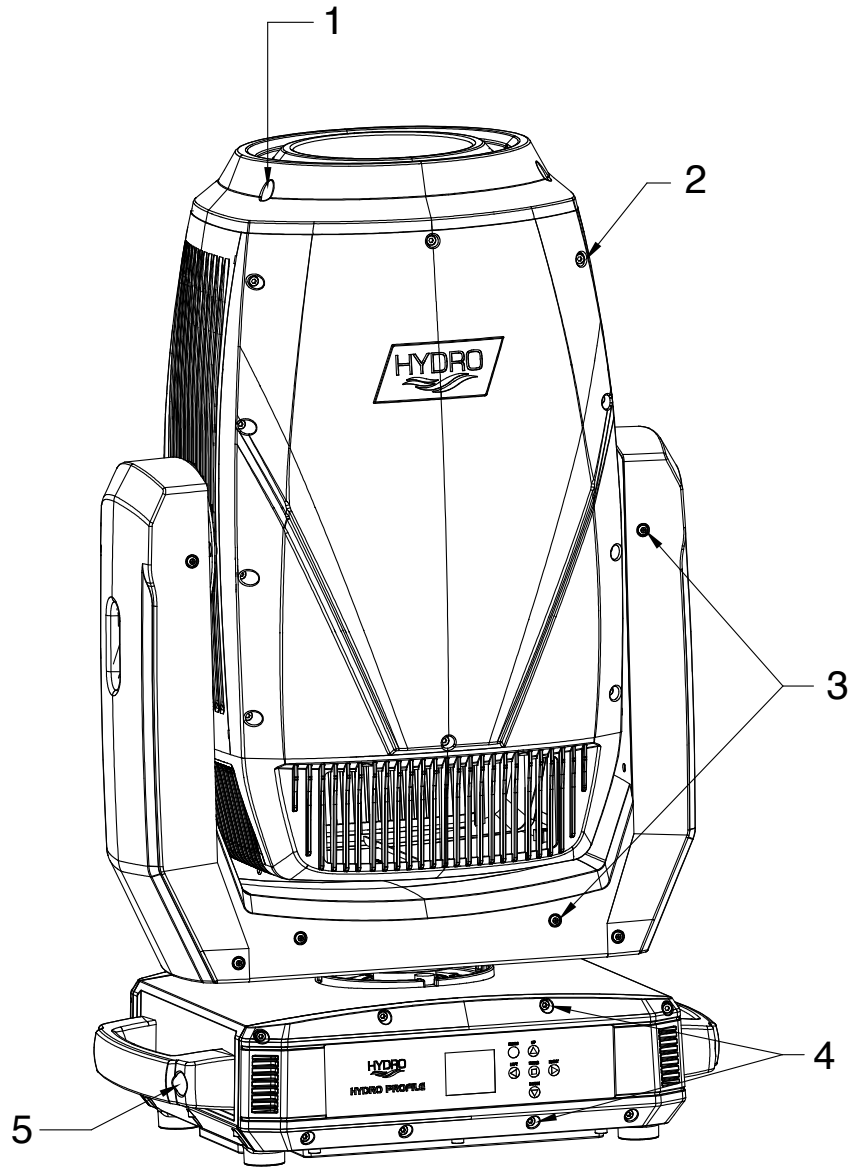

| Zone No. | Description | Quantity | Torque Spec |
|----------|------------------------|------------------------|--|
| 1 | Lens Frame | 4 | 4.3 ± 0.6 lbf-in (5.0 ± 0.7 kgf-cm) |
| 2 | Main Head Covers | 10 per side (20 total) | 6.9 ± 0.6 lbf-in (8.0 ± 0.7 kgf-cm) |
| 3 | Arm Covers | 6 per side (12 total) | 4.3 ± 0.4 lbf-in (5.0 ± 0.5 kgf-cm) |
| 4 | Base Front/Rear Covers | 8 per side (16 total) | 6.9 ± 0.6 lbf-in (8.0 ± 0.7 kgf-cm) |
| 5 | Carry Handles | 2 per handle (4 total) | 6.9 ± 0.6 lbf-in (8.0 ± 0.7 kgf-cm) |

TORQUE SETTINGS FOR SCREWS

TORQUE DRIVERS (Recommended): UTICA TS-30 (Shown)

TORQUE DRIVER (Alternate):

- Proto J6107A
- Wiha 28887



CAUTION! DO NOT OVER TORQUE SCREWS AS THIS CAN CAUSE LEAKAGE ISSUES! TO CONFIRM THE IP65 INTEGRITY AFTER A LAMP REPLACEMENT, TEST THE FIXTURE USING THE IP TESTER. CONTACT ADJ SERVICE FOR MORE DETAILS.



CAUTION! THE USE OF PROTECTIVE GLOVES AND SAFETY GOGGLES IS STRONGLY RECOMMENDED WHILE PERFORMING THE IP PRESSURE TEST! AVOID PLACING YOUR FACE, EYES, HANDS, ETC IN CLOSE PROXIMITY TO THE FIXTURE'S LENS WHILE PERFORMING THE TEST!



| IP PRESSURE TESTING PARAMETERS | | |
|--------------------------------|---------------------|------------------|
| Maximum Pressure | Minimum Pressure | Steady/Hold Time |
| 3.3 psi (23 KPa) | 2.9 psi (20 KPa) | 15 sec |

DIMENSIONAL DRAWINGS

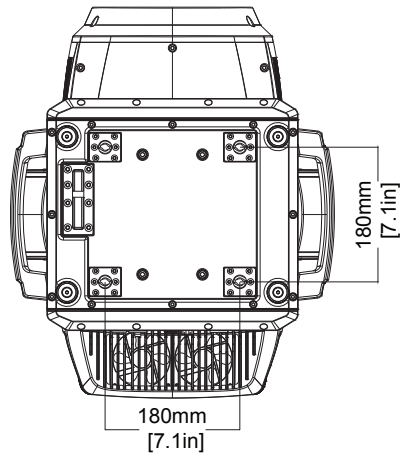
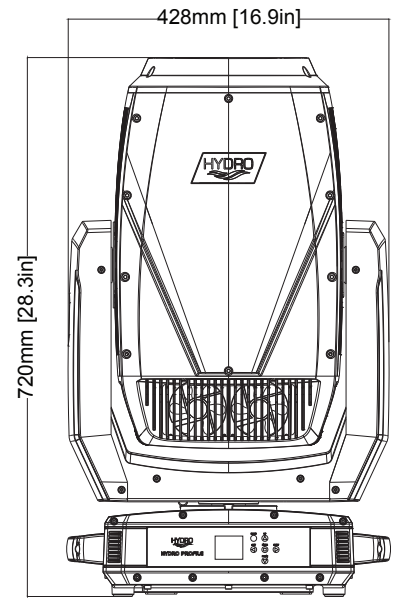
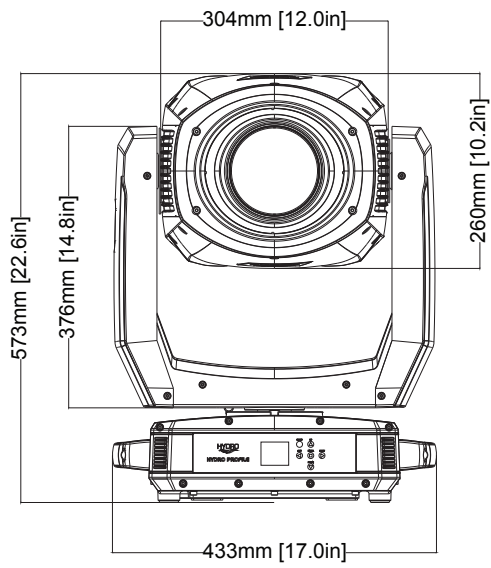
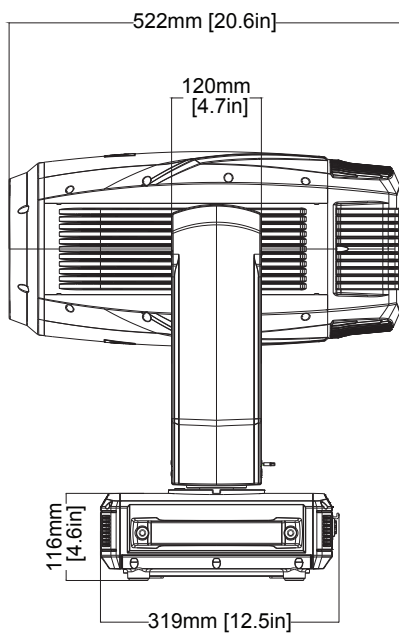

Dimensions may not be drawn to scale

ERROR CODES

| | |
|-------------|---------------|
| Pan | Prism1 |
| Tilt | Prism1 Rot |
| Cyan | Prism2 |
| Magenta | Prism2 Rot |
| Yellow | Animation |
| CTO | Animation Rot |
| Color Wheel | Blade Rot |
| Gobo | LED Fan |
| Rot Robo | Base Fan |
| Fixed Gobo | Gobo Fan |
| Focus | LED Temp |
| Zoom | Base Temp |

SPECIFICATIONS

Light Source:

- 660W Cool White LED Engine (50,000 hr.)
- 25,000+ Lumens

Features:

- Motorized Focus
- 2 Frost Filters
- Motorized Zoom: 6 ~ 45 degrees
- 4 Blade Framing System (Rotatable)
- Iris
- Animation Wheel
- 2 Prism FX: Rotating 6-facet Linear & rotating 4-facet Circular
- 0-100% smooth dimming
- Various strobe speeds
- 2 cooling fans

Color:

- CMY color mixing system
- Variable CTO flag
- Color wheel with 7 dichroic colors + white (includes CTB and High CRI filters)
- Colors on wheel are removable and replaceable

Gobo Wheels:

- (1) Rotating Gobo wheel with 7 Gobos
- (1) Static Gobo wheel with 8 Gobos
- All Gobo's are replaceable
- Gobo Shake Effect on both wheels
- Aluminum Gobo size: 23mm (outer); 19mm (viewable); 0.5mm (thickness)
- Glass gobo size: 23mm (outer); 19mm (viewable); 3.3mm (thickness)

Prism Wheel:

- Prism Wheel 1: Rotatable 6-facet Linear
- Prism Wheel 2: Rotatable 4-facet Circular
- Both Prisms are indexable

Frost Filters:

- Frost 1: Heavy frost for wash effect
- Frost 2: Medium frost creates lightly blurred edges for Gobo and Prism FX

Control:

- 3 DMX Channel Modes: 36/50/57
- Color LCD display with 6-button function menu
- Control Mode: DMX512 or internal programs
- 6 Dim Modes: Standard, Stage, TV, Architectural, Theatre, Stage2
- 4 Dim Curves: Square, Linear, Inv. Square and S. Curve
- Selectable LED Refresh Rates (900 Hz~25K Hz)
- 0-100% smooth dimming
- Various strobe speeds
- With Wired Digital Communication Network
- RDM (Remote Device Management)

Pan/Tilt:

- Pan: 540 degrees
- Tilt: 270 degrees

Connections:

- DMX Connections: 5-pin XLR In/Out
- Power Connections: IP65 PowerLock Input

Electrical:

- Multi-voltage operation: 100-240V, 50/60Hz
- Max power consumption: 1088W

Dimensions & Weight:

- Dimensions (LxWxH): 12.5" x 17.0" x 28.3"
(319x433x720mm)
- Weight: 84.9 lbs (38.5 kg)

Approvals / Rating:

- ETL Approved / CE Certified
- IP65 with Marine Coated Exterior and conformal coated PCBs

Specifications and manual are subject to improvement without prior written notice.

