

Technical Datasheet

Overview

- 2 x Mic/Line Inputs with GS Preamps.
- Global 48V Phantom power.
- Switchable Hi-Z Input.
- 2 x Stereo Line Inputs.
- 2 in, 2 out, 24-bit/96kHz USB Audio Interface.
- Headphone Output.
- Hi-Pass filter on microphone inputs.
- HF & LF EQ adjustable pots on all channels.
- PFL select to headphone output.

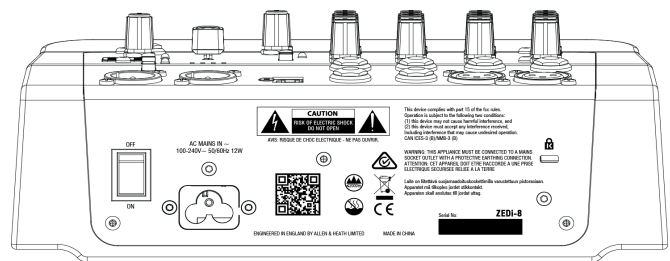

Dimensions

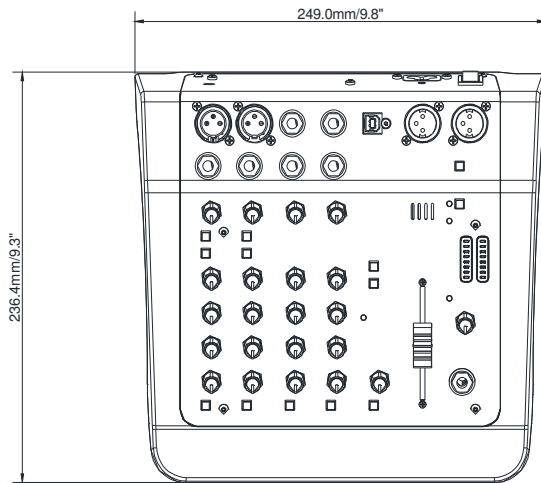

HEIGHT: 88.9mm (3.5")

WIDTH: 249mm (9.8")

DEPTH: 236.4mm (9.3")

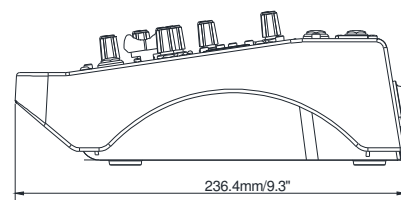
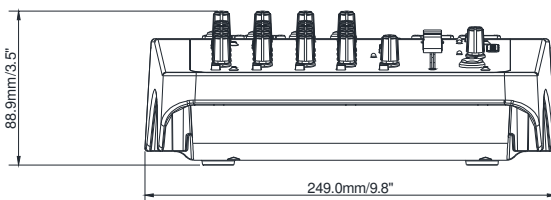

A&E Specifications

The mixer shall be a compact and portable analog mixer with two mono and two stereo input channels mixing to a stereo Main Mix output. The mixer shall weigh no more than 1.36kg (3lbs).

Each mono input channel shall have an XLR Microphone connector and Line level quarter-inch jack connector and shall be equipped with High Pass Filter and 2-band equaliser circuit

Stereo input channels shall use quarter-inch jack connectors, and shall have a fixed 2-band EQ.

All XLR Microphone inputs shall have the ability to power Condenser Microphones requiring 48 Volt Phantom Power. This shall be switchable and have a red LED to indicate activation.

There shall be two high-impedance jack inputs on mono channels, which can handle a normal line level or a low level input directly from a guitar pickup, allowing instruments such as guitars to be plugged straight into the mixer without the need for a DI box.

XLR Mic input characteristics shall conform to a Gain Min/Max of 6dB to 60dB with a maximum Input Level of 13dBu.

Quarter-inch jack Line input characteristics shall conform to a Gain Min/Max of -14dB to 40dB with a maximum Input Level of 18dBu.

The mixer shall have a 2in/2out USB Audio Interface which will allow for a total channel count of eight. The audio interface shall operate at 24bit/96kHz as standard, be class compliant for Mac and iOS devices and be compatible with Windows.

The mixer surface shall include independent rotary control for each input channels gain, level and mix. Each channel should have individual Pan control and a [PFL] switch to route to the headphone output. An LED shall indicate when a [PFL] channel is active.

The Headphone output should use a quarter-inch jack connector with a rotary to control output level.

The L&R outputs shall have XLR connectors and will be controlled via a mix output fader. Level indication shall be via a stereo eight segment LED display.

It shall have a built in power supply accepting AC mains voltages of 100~240V, 50/60 Hz, 12W max via an earthed 3-pin IEC C6 male connector mounted on the rear chassis.

A switch shall be provided near the mains inlet to isolate the mixer from the incoming mains supply.

Recommended operating temperature for the mixer shall be 5 to 35 degrees Celsius.

The unit shall be the Allen & Heath ZEDi 8.

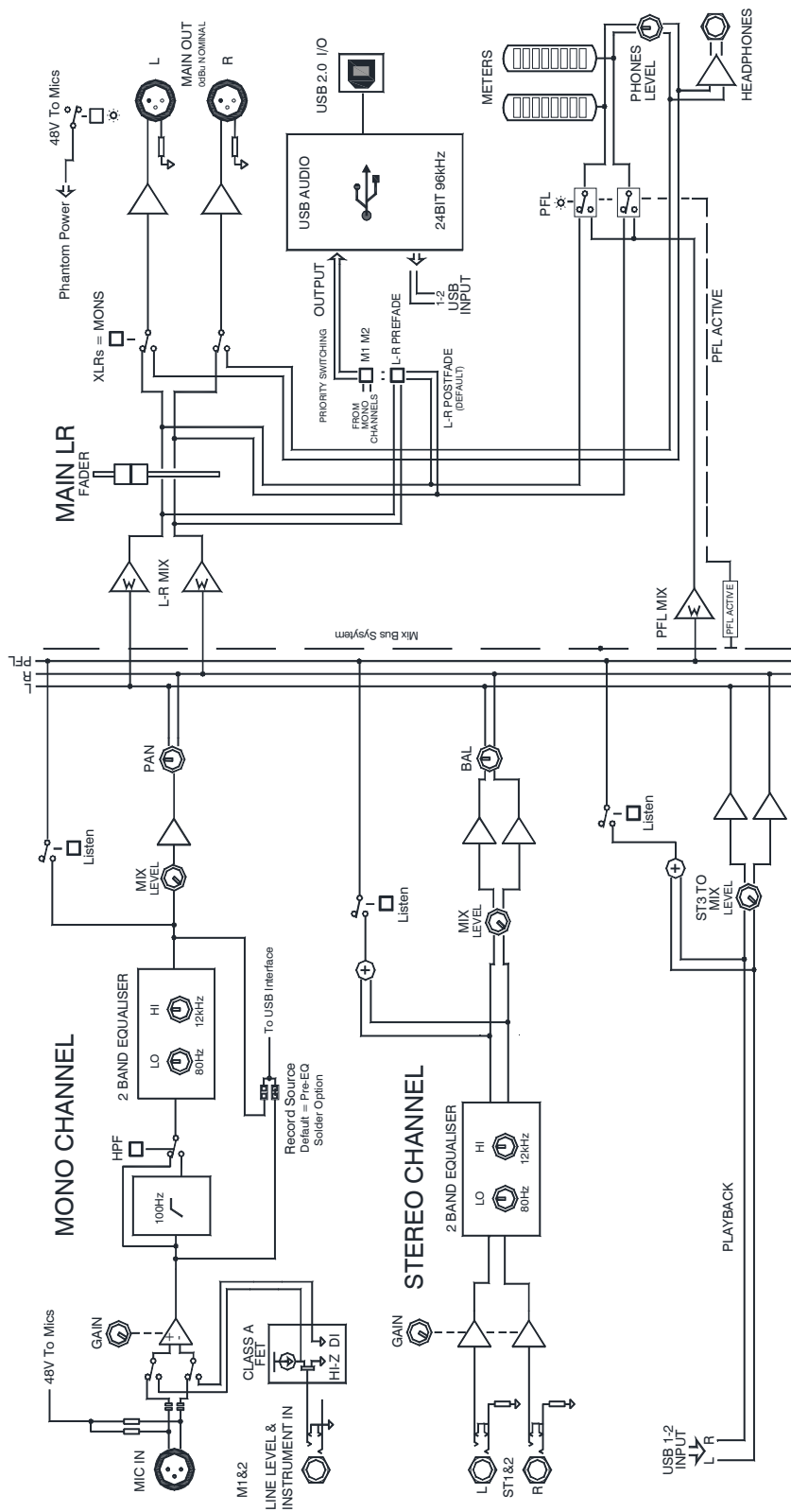

ZEDI-8 BLOCK DIAGRAM

Mixer Specification

Model	ZED-6	ZED-6FX	ZEDi-8	ZEDi-10	ZEDi-10FX
Type	Analog	Analog	Analog	Analog	Analog
Channels	6	6	8	10	10
Inputs - Mic Preamps	2 x XLR	2 x XLR	2 x XLR	4 x XLR	4 x XLR
Inputs - Line	2 x TRS (CH 1- 2) 4 x TRS (CH 3-4 ST)	2 x TRS (CH 1-2) 4 x TRS (CH 3-4 ST)	2 x TRS (CH 1-2) 4 x TRS (CH 3-4 ST)	4 x TRS (CH 1-4) 4 x TRS (CH 5-6 ST)	4 x TRS (CH 1-4) 4 x TRS (CH 5-6 ST)
Outputs - Main	2 x XLR (Main)	2 x XLR (Main)	2 x XLR (Main)	2 x XLR (Main)	2 x XLR (Main)
Outputs - Other	-	-	-	2 x RCA (Monitor)	2 x RCA (Monitor)
Headphones	1 x 1/4"	1 x 1/4"	1 x 1/4"	1 x 1/4"	1 x 1/4"
Send/Return I/O	-	1 x 1/4" (FX)	USB	2 x 1/4" (1x AUX, 1x FX)	2 x 1/4" (1x AUX, 1x FX)
Phantom Power	2	2	2	4	4
EQ Bands	2-band, (CH 1-2) 2-band (CH 3-4 ST)	2-band, (CH 1-2) 2-band (CH 3-4 ST)	2-band, (CH 1-2) 2- band (CH 3-4 ST)	3-band (CH 1-4) 2-band (CH 5 ST)	3-band (CH 1-4) 2-band (CH 5 ST)
Aux / FX Sends	-	1 x Post (Per Channel)	-	1 x Pre, 1 x Post (Per Channel)	1 x Pre, 1 x Post (Per Channel)
Busses/Groups	Stereo Bus	Stereo Bus	Stereo Bus	Stereo Bus	Stereo Bus
Channel Inserts	-	-	-	-	-
Effects	-	Yes	-	-	Yes
Computer Connectivity	-	-	1 x USB	1 x USB	1 x USB
Rack-mountable	No	No	No	No	No
Height	3.5"	3.5"	3.5"	3.8"	3.8"
Width	9.8"	9.8"	9.8"	13.1"	13.1"
Depth	9.3"	9.3"	9.3"	10.8"	10.8"
Weight	2.8 lbs.	3 lbs.	3 lbs.	4.85 lbs.	5.1 lbs.